

Important information Serious risk of injury

When working on the engine, e.g. when adjusting the drive belts and clutch, or when changing oil, it is important not to start the engine. The engine could be damaged, but more importantly there is a serious risk of injury.

For this reason, always secure the starting device or disconnect a battery cable before working on the engine. This is especially important if the engine has a remote starter or automatic starting.



WARNING!

This warning symbol and text can be found next to those maintenance items where it is particularly important to bear in mind the risk of injury.

Operator's manual DI16 XPI Marine engine en-GB 3 237 449

Issue 12.0



WARNING: This engine can expose you to chemicals including diesel engine exhaust which is known to the State of California to cause cancer and birth defects or other reproductive harm.

For exposures to diesel engine exhaust:

- Always start and operate the engine in a well-ventilated area.
- If in an enclosed area, vent the exhaust to the outside.
- Do not modify or tamper with the exhaust system.
- Do not idle the engine except as necessary.

For more information go to www.P65Warnings.ca.gov.

Start of warranty	3	Checking the fuel level.	64
Introduction	4	Draining and renewing the water separating pre-filter	65
Certification	4	Draining and renewing the single water separating prefilter.	66
Power classes	6	Draining the reversible water separating prefilter 67	
Environment and safety	7	Renewing the reversible water separating prefilter	69
Environmental liability	7	Renewing the reversible fuel filter, 16 litre marine engine with XPI	71
Information on parts with particularly hazardous substances	7	Renewing the fuel filter	72
Safety	7	Bleeding the fuel system	73
Warnings and advisories	9	Bleeding the fuel system using a hand pump, 16 litre marine engine, XPI	75
Scania Engines engine warranty for marine engines	14	Other	77
Emission control systems warranty.	14	Checking the drive belt	77
Emission control system warranty statement	14	Checking for leakage	78
Engine data plate	17	Checking and adjusting the valve clearance .	79
Component identification	18	Quality requirements for fuel	82
Starting and driving	20	Diesel	82
Checks before first start	20	Renewable diesel (HVO)	85
checks before driving	20	Gas-to-liquids (GTL)	85
Starting the engine	20	Preparing the engine for storage	86
Driving	21	Preservative products	86
Engine shutdown.	23	Preparations for storage	87
Checks after driving	23	Technical data	89
Maintenance	24	General data	89
Maintenance interval.	25	Lubrication system	89
Lubrication system	27	Intake system	90
Oil grade	27	Cooling system.	90
Oil analysis	29	Fuel system.	90
Checking the oil level	30	Electrical system	90
Changing the oil	31	Material content	91
Maximum angles of inclination during operation 32		Tightening torque for screw joint	92
Cleaning the centrifugal oil cleaner	33	Screws and nuts	92
Operational testing of the centrifugal oil cleaner 37		Hose clamps	93
Renewing the oil filter.	38	Scania Assistance	94
Air cleaner	39		
Reading the vacuum indicator.	39		
Renewing the filter element	39		
Renewing the safety cartridge.	40		
Renewing an air filter with a non-renewable element.	40		
Cooling system	41		
Coolant	41		
Checking the coolant level	45		
Checking the coolant's antifreeze and corrosion protection	45		
Checking the sacrificial anodes.	46		
Checking the sea water pump impeller.	47		
Changing the coolant and cleaning the cooling system	49		
Fuel system	64		
Cleanliness requirements	64		

Start of warranty

The more Scania knows about you, your company and your equipment, the more effectively we can adapt our services to you. If you have started to use a new Scania engine, it is very important that you send in the warranty start report to us immediately. Quite simply, Scania needs to register all the details on engine ownership etc. in order to carry out monitoring for you.

You can report the start of the warranty on the Scania website: www.scania.com.

Note:

If you do not send in the warranty report, the engine is not covered by the accompanying Scania warranty.

Also fill in below the details you enter in the warranty report. These details can facilitate contact with a workshop, for example. The engine serial number is on the engine data plate and is also engraved on the cylinder block.

Engine serial number (e.g. 1111111)

Ship ID (for example MMSI 111111111 or IMO 1111111)

Start date (yyyy-mm-dd)

Company name

Contact person

Telephone number

E-mail address

Address

Postcode

Postal town

State/County

Country

Introduction

This Operator's manual describes the operation and maintenance of Scania marine engines.

The engines are direct-injection, liquid-cooled, four-stroke diesel engines with turbochargers.

The engines are available with different output and engine speed settings. The engine power of the engine ordered is indicated on the engine data plate.

Note:

Only standard components are described in the operator's manual. Information about special equipment is contained in instructions from the various manufacturers.

To ensure the maximum performance and the longest service life for the engine remember the following:

- Read through the Operator's manual before starting to use the engine. Even regular users of Scania engines will get new information from the Operator's manual.
- Always follow the maintenance instructions.
- Read the section on safety carefully.
- Get to know your engine so that you know what it can do and how it works.
- Always contact an authorised Scania workshop for maintenance and repairs.

The information in this Operator's manual was correct at the time of going to press. Scania reserves the right to make alterations without prior notice.

Note:

Always use Scania spare parts for maintenance and repair.

Certification



IMPORTANT!

For Scania to guarantee that the engine corresponds to its certified configuration, and take responsibility for any damage and injuries that occur, maintenance must be carried out in accordance with the instructions in this Operator's manual.

An emissions certified engine fulfils the emissions requirements for a particular range of application.

On each emissions certified engine there is a label which shows which requirements the engine fulfils. Scania guarantees that each such engine fulfils the emissions requirements for the range of application for which it is certified.

The following are required for the certified engine to fulfil the emissions requirements once it has been taken into service:

- Maintenance is to be carried out in accordance with the instructions in this Operator's manual.
- Maintenance and repairs of injection equipment are to be carried out by an authorised Scania workshop.
- The engine may only be modified with equipment that has been approved by Scania.
- Seals may be broken and setting data edited only once approval has been granted by Scania. Modifications may be made by authorised personnel only.
- Modifications affecting the exhaust and intake systems must be approved by Scania.

Otherwise, the instructions in the Operator's manual for the running and maintenance of the engine shall apply. Follow the safety precautions on the following pages.

DECLARATION OF CONFORMITY

With requirements of Directive 2013/53/EU

ENGINE MANUFACTURER	Scania CV AB
ADDRESS	SE-151 87 Södertälje
COUNTRY	Sweden
NOTIFIED BODY FOR RCD	DNV
ADDRESS	Brooktorkai 18, 20457 Hamburg
COUNTRY	Germany
ID NUMBER	0098
ENGINE TYPE	Scania Marine Inboard Engine, 4-Stroke
FUEL TYPE	Diesel
MODULE	B + D

The following engines meet the exhaust emission requirements of Directive 2013/53/EU, when installed in a recreational craft, in accordance with Scania CV supplied instructions. The engines must not be put into service until the recreational craft into which it is to be installed has been declared in conformity, if so required, with the relevant provision of the above Directive.

COVERED ENGINE(S)

TYPE DESIGNATION	CERTIFICATE NUMBER Module B (Exhaust Emissions)	CERTIFICATE NUMBER Module D (Conformity to type based on quality assurance of the production process)
DI16 304M	RCDB00000AU	RCDD000000D

Scania CV AB hereby declares that the engines listed above conform to European Union directives, standards and normative documents identified in this declaration.

Name: Joel Granath
Senior Vice President Scania Power Solutions

(Person empowered to sign on behalf of engine manufacturer)

Date (Year-Month-Day): 2023-02-02

Signature:

Power classes

Scania supplies engines in 5 different power classes:

IFN, Intermittent service: Intended for continuous operation and an unlimited number of operating hours per year at a total load factor of 100% provided that the engine speed is at a minimum of 85% of the nominal value of the engine. If the engine speed is below 85% of the nominal value, the rated power is available for 1 hour in a 6-hour period and the average load must not exceed 80% of the power at the current rotational speed.

Patrol craft long: Intended for periodic use, where the rated power is available for 1 hour per 6-hour period. In between periods of operation at full load, the engine speed must be reduced by at least 10% of the maximum engine speed attained. The total operating time must not exceed 2,000 hours per year.

Patrol craft short: Intended for periodic use, where the rated power is available for 1 hour per 12-hour period. In between periods of operation at full load, the engine speed must be reduced by at least 10% of the maximum engine speed attained. The total operating time must not exceed 1,200 hours per year.

Pleasure craft: Intended for periodic use, where the rated power is available for 1 hour per 20-hour period. The total load factor must not exceed 50% of the rated power. The total operating time must not exceed 500 hours per year. Engines marked for recreation are only suitable for this power class.

The engine serial numbers and power classes for the engines that are used in this installation should be listed below: You can find the power class of your engine in the engine type data sheet on the Scania website, www.scania.com.

Engine serial number:

Motor type:

Engine power:

_____ kW at _____ rpm

IFN, Intermittent service

Patrol craft long

Patrol craft short

Pleasure craft (for recreational engine)

Environment and safety

Environmental liability

Scania develops and produces engines that are as environmentally-friendly as possible. Scania has made major investments in the reduction of harmful exhaust emissions in order to fulfil the environmental requirements in force in almost every market.

At the same time, we have been able to maintain a high level of performance quality and operating economy for Scania engines. To maintain these throughout the entire service life of the engine, it is important for the user to follow the instructions on running, maintenance and fuel, lubricating oil and coolant as outlined in the Operator's manual.

Other green initiatives taken include ensuring that, following maintenance and repair, waste that is harmful to the environment (for example oil, fuel, coolant, filters and batteries) is disposed of accordance with the applicable environmental requirements.

Information on parts with particularly hazardous substances

Note:

A number of component parts on the engine contain materials with particularly hazardous substances.

The substances have properties that can have a serious and lasting effect on human health and the environment.

If a part or component parts contain more than 0.1% by weight of a substance listed on the REACH candidate list, the supplier must provide information about the substance.

The requirement is defined in Article 33 of the REACH Regulation (EC 1907/2006) and applies within the EU, Liechtenstein, Norway and Iceland.

<https://echa.europa.eu/candidate-list-table>.

A list of engine parts containing substances in the candidate list is provided by Scania.

<https://sure.scania.com/reach>.

According to Article 9 of the EU Waste Framework Directive ((EU) 2018/851), manufacturers of parts containing more than 0.1% by weight of a particular hazardous substance must communicate this to the EU Chemicals Agency (ECHA).

Scania supplies individual notification numbers in SCIP for affected vehicles.

<https://sure.scania.com/>

The notification number can be used to search the ECHA SCIP database.

<https://echa.europa.eu/scip-database>

Safety

The following pages contain a summary of the safety precautions to be complied with when operating and maintaining Scania engines. The equivalent text can also be found under the relevant maintenance item.

To prevent damage to the engine and to ensure that it runs optimally, follow the instructions in the warnings and advisories.

If the instructions are not followed, the warranty can cease to apply.

Different types of advisory

Warning!

All advisories preceded by **Warning!** are very important. They warn of serious faults and incorrect operation that could lead to personal injury. Example:



WARNING!

Block the starting device when working on the engine. If the engine starts unexpectedly, there is a serious risk of injury.

Important!

Advisories preceded by **Important!** warn of faults and incorrect operation that could lead to equipment being damaged. Example:



IMPORTANT!

An excessive coolant temperature can cause engine damage.

Please note:

Advisories preceded by **Note:** refer to information important to ensure the best possible operation and functionality. Example:

Note:

Leave the engine off for at least 7 minutes before you check the oil level.

Environment

This Operator's manual contains specially highlighted text with instructions to help protect the environment during maintenance. Example:



Environment

Use a suitable container. The fuel collected must be disposed of as specified in national and international laws and regulations.

Warnings and advisories

Smoking



WARNING!

Smoking is prohibited

- in the vicinity of flammable or explosive material, e.g. fuel, oils, batteries, chemicals
 - when refuelling and in the vicinity of the filling station
 - when working on the fuel system
-

Safety precautions for running the engine

Daily maintenance

Always carry out a visual inspection of the engine and engine compartment before starting the engine or when the engine has been switched off after operation.

This inspection should be done to detect fuel, oil or coolant leaks, or anything else that may require corrective action.

Fuel



WARNING!

The wrong fuel grade can cause breakdowns or stoppages by causing the injection system to malfunction. This can cause damage to the engine and, possibly, personal injury.



REQUIREMENT!

Use only fuel which fulfils the requirements in the [Quality requirements for fuel](#) section.

Refuelling



WARNING!

During refuelling there is a risk of fire and explosion. The engine must be switched off and smoking is prohibited.

Never overfill the tank as the fuel needs space to expand. Make sure that the filler cap is fully closed.

Hazardous gases



WARNING!

Only start the engine in a well-ventilated area. The exhaust gases contain carbon monoxide and nitrogen oxides, which are toxic.

When the engine is run in an enclosed space, there must be an effective device to extract exhaust gases and crankcase gases.

Starter lock



IMPORTANT!

If the instrument panel is not fitted with a starter lock, the engine compartment should be locked to prevent unauthorised personnel from starting the engine. Alternatively, a lockable master switch or battery master switch can be used.

Starter gas



WARNING!

Never use starter gas or similar agents to help start the engine. This can cause an explosion in the intake manifold and possible injury.

Driving



WARNING!

The engine must not be run in environments where there is a risk of explosion, as all of the electrical or mechanical components can generate sparks.

Approaching a running engine always poses a safety risk. Parts of the body, clothes or dropped tools can get caught in rotating parts such as the fan and cause injury. For personal safety all rotating parts and hot surfaces must be fitted with guards.

Safety precautions for handling materials

Fuel and lubricating oil



WARNING!

All fuels and lubricants as well as many chemicals are flammable. Always follow the instructions on the relevant packaging.

The work must be carried out on a cold engine. Fuel leaks and spillages on hot surfaces can cause fire.

Store used rags and other flammable materials safely so as to avoid spontaneous combustion.

Batteries



WARNING!

The batteries contain and form oxyhydrogen gas, particularly during charging. Oxyhydrogen gas is flammable and highly explosive.

There must be no smoking, naked flames or sparks near the batteries or the battery compartment. Incorrect connection of a battery cable or jump lead can cause a spark, which can cause the battery to explode.

Chemicals



WARNING!

Most chemicals such as glycol, anti-corrosive agents, preservative oils and degreasing agents, are hazardous to health. Some chemicals, such as preservative oil, are also flammable. Always follow the safety precautions on the packaging.

Store chemicals and other materials which are hazardous to health in approved and clearly marked containers, where they are inaccessible to unauthorised persons.



Environment

Excess and used chemicals must be disposed of as specified in national and international laws and regulations.

Safety precautions for maintenance

Switch off the engine



WARNING!

Working on a running engine always poses a safety risk. Parts of the body, clothes or dropped tools can get caught in rotating parts and cause injury.

Always switch off the engine before carrying out maintenance, unless otherwise indicated.

Make it impossible to start the engine: Remove any starter key, or cut the power using the main power switch or battery master switch and lock them.

Fix a warning plate somewhere appropriate, showing that work is being carried out on the engine.

Hot surfaces and fluids



WARNING!

There is always a risk of sustaining burns when an engine is hot. Particularly hot parts are branch pipes, turbochargers, oil sumps, and hot coolant and oil in pipes and hoses.

Lubrication system**WARNING!**

Hot oil can cause burns and skin irritation. Wear protective gloves and eye protection when changing hot oil.

Make sure that there is no pressure in the lubrication system before starting work on it.

Make sure that the oil filler cover is fitted when starting and driving in order to avoid oil escaping.

**Environment**

Used oil must be disposed of as specified in national and international laws and regulations.

Cooling system**WARNING!**

Never open the coolant filler cap when the engine is hot. Hot coolant and steam may spray out and cause burns. If the cap has to be opened do it slowly to release the pressure before removing the cap. Wear protective gloves as the coolant is still very hot.

Avoid skin contact with coolant as this may cause irritation to the skin. Wear eye protection and gloves when handling coolant.

Ethylene glycol can be fatal if ingested.

**Environment**

Used coolant must be disposed of as specified in national and international laws and regulations.

Fuel system**WARNING!**

Maintenance and repairs of injection equipment are to be carried out by an authorised Scania workshop.

Always use Scania spare parts for the fuel and electrical systems. Scania spare parts are designed to minimise the risk of fire and explosion.

**Environment**

Use a suitable container. The fuel collected must be disposed of as specified in national and international laws and regulations.

Electrical system**WARNING!**

Switch off the engine and switch off the power by disconnecting the electrical cables to the battery. External power supplies to extra equipment in the engine must also be disconnected.

Always use Scania spare parts for the fuel and electrical systems. Scania spare parts are designed to minimise the risk of fire and explosion.

Electric welding



WARNING!

When carrying out welding work on and near the engine, disconnect the battery and alternator leads. Pull out the multi-pin connector for the engine control unit as well.

Connect the welding clamp close to the component to be welded. The welding clamp must not be connected to the engine, or so that the current can cross a bearing.

When welding is finished:

1. Connect the alternator and engine control unit cables.
2. Connect the batteries.

Batteries



WARNING!

The batteries contain highly corrosive sulphuric acid. Take care to protect your eyes, skin and clothes when charging or handling batteries. Wear protective gloves and eye protection.

If sulphuric acid comes in contact with the skin: Wash with soap and plenty of water. If it gets in your eyes: Rinse immediately with plenty of water and seek medical attention.



Environment

Used batteries must be disposed of as specified in national and international laws and regulations.

Before starting



WARNING!

Ensure that all guards are in place before starting the engine. Ensure that no tools or other objects have been left on the engine.

The air filter must be fitted before starting the engine. Otherwise there is a risk of objects being sucked into the compressor impeller or of injury if you come into contact with the air filter.

Cybersecurity



IMPORTANT!

The machine manufacturer is responsible for ensuring that all engine management communication is protected against all forms of cyber attack.

The machine manufacturer is also responsible for ensuring the engine can be operated safely in all conditions, including the option of shutting off the engine in the event of disruption to communications with or without engine control.

Scania Engines engine warranty for marine engines

Emission control systems warranty



IMPORTANT!

This section is only applicable to engines used in the U.S.A, and to engines without exhaust gas aftertreatment system (SCR system).

This section is not applicable to incorrectly installed or non-Scania low pressure fuel system components.

Table of Contents

General warranty provisions	12
Warranty period	12
Parts covered by the Warranty	13
General warranty limitations	13
Specific warranty exclusions	14
Customer support	14

Emission control system warranty statement

General warranty provisions

The emission control systems of your new Scania Engines (“Scania”) marine diesel engine were designed, built and tested using genuine parts, and were certified as being in conformity with federal emission control regulations. Scania warrants to the original owner, and to each subsequent owner, of a new Scania marine diesel engine (“You”) that the emission control system of your engine:

1. Was designed, built and equipped so as to conform at the time of sale with all applicable regulations under Section 213 of the Clean Air Act, 42 U.S.C. § 7547, and
2. Is free from defects in material and workmanship which would cause such engine to fail to conform to applicable regulations for its warranty period.

Warranty period

This warranty shall apply for one of the following periods, whichever occurs first:

- A period of operating hours equal to at least 50 percent of the engine's useful life in operating hours, or
- A period of years equal to at least 50 percent of the engine's useful life in years;
- Except that the warranty period shall apply for a period not less than any mechanical warranties provided by Scania to the owner.

The warranty period shall begin:

- On the date the marine vessel is delivered to the first retail purchaser, or
- If the marine vessel is placed in service for demonstration purposes prior to sale at retail, on the date the engine is first placed in service.

The emission-related warranty is valid for:

- 500 hours or 5 years for recreational engines, whichever comes first.
- 5000 hours or 5 years for commercial engines, whichever comes first.

Parts covered by the Warranty

The following is a list of parts considered a part of the Emission Control Systems and is covered by the Emission Warranty for engines which were built to conform to applicable U.S. Environmental Protection Agency regulations:

1. Fuel system
2. Air-induction system
 - a) Intake manifold
 - b) Turbocharger system
 - c) Charge air cooler system
3. Exhaust manifold
4. Combustion chamber
 - a) Piston
 - b) Cylinder head
5. Crankcase ventilation
6. Sensors
 - a) Engine speed sensors
 - b) Oil pressure sensor
 - c) Coolant temperature sensor
 - d) Coolant level sensor
 - e) Charge air pressure sensor
 - f) Charge air temperature sensor
7. Electronic control unit
8. Components used in the above mentioned systems



IMPORTANT!

This list does not include all expendable maintenance parts. Expendable emission related parts requiring scheduled maintenance are warranted until their first scheduled replacement point. See Specific warranty exclusions below.

General warranty limitations

To retain the dependability of the exhaust emission control originally built into your Scania marine diesel engine, it is essential that the engine is installed according to Scania installation instructions and emission certificates.

In addition, You are responsible for the performance of all scheduled maintenance or repairs on your new Scania marine diesel engine. Scania may deny a warranty claim if your failure to perform maintenance resulted in the failure of the warranted part.

Receipts covering the performance of regular maintenance should be retained in the event questions arise concerning maintenance. The receipts should be transferred to each subsequent owner of the marine vessel with the emission warranted engine.

The Warranty covers the cost of repair and replacement parts and services of warranted components and systems performed by an authorized Scania distributor or dealer using genuine Scania parts. You may elect to have maintenance, replacement or repair of these components and systems performed by any repair establishment or individual without invalidating the Warranty.

The use of other than Scania replacement parts also does not invalidate the warranty on other components unless such parts cause damage to warranted parts. However, the cost of such services or parts will not be covered by the Warranty.

If you install the engine in a way that makes the engine's emission control information label hard to read during normal engine maintenance, you must place a duplicate label on the vessel, as described in 40 CFR 1068.105.



IMPORTANT!

If other than Scania parts are used for maintenance, repair or replacement, the owner should obtain assurance that such parts are warranted by their manufacturer to be equivalent to genuine Scania parts.

Specific warranty exclusions

This warranty does not cover:

1. Malfunctions in any part caused by any of the following: misuse, abuse, improper adjustments, modifications, alteration, tampering, disconnection, improper or inadequate maintenance, or use of fuels not recommended for the engine as described in the Operator's Manual.
2. Engine installation, including cooling system, intake system and exhaust system installation, that is not completed in accordance with the Scania installation instructions and emissions certificate for this engine type, unless engine installation is the engine manufacturer's fault or responsibility.
3. Damage resulting from accidents, acts of nature or other events beyond the control of Scania.
4. The replacement of expendable maintenance items such as filters, hoses, belts, oil, thermostat, exhaust system and coolant made in connection with scheduled maintenance services once these parts have been replaced.
5. Replacement items which are not genuine Scania parts or not authorized by Scania as of equal quality to the original parts.
6. Inconvenience, loss of use of the marine vessel or commercial loss.
7. Any marine vessel on which the actual use cannot be accurately determined.
8. Any marine vessel operating outside the United States.

Customer support

In the event that You do not receive the warranty service to which You believe You are entitled under the Warranty, or if You need additional support or information concerning the Warranty, please contact:

Scania USA, Inc.

Address: 121 Interpark Blvd, suite 1002, 78216, San Antonio, Texas

Mailing address: 121 Interpark Blvd, suite 1002, 78216, San Antonio, Texas

Telephone: +1 210 403 0007

Fax: +1 210 403 0211

E-mail: na.contact@scania.com

Engine data plate

The engine data plate indicates, in the form of a code, the engine type, its size and applications. It also indicates the engine power and the nominal engine speed. The engine EU type approval for exhaust emissions is indicated under *Output*.

The engine serial number is stamped onto the top of the cylinder block at the front right.

Example: DI16 076M

- DI Turbocharged diesel engine with water-cooled charge air cooler.
- 16 Displacement in whole dm³.
- 076 Performance and certification code. The code indicates, together with the application code, the normal gross engine output.
- M Code for application. M means for marine use.

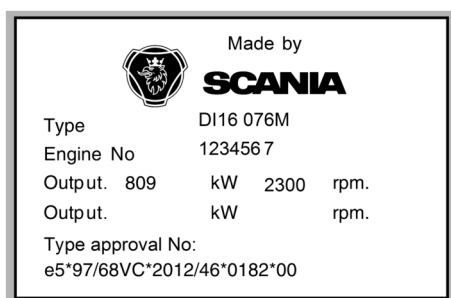

357 566

Example of an engine data plate.

Component identification

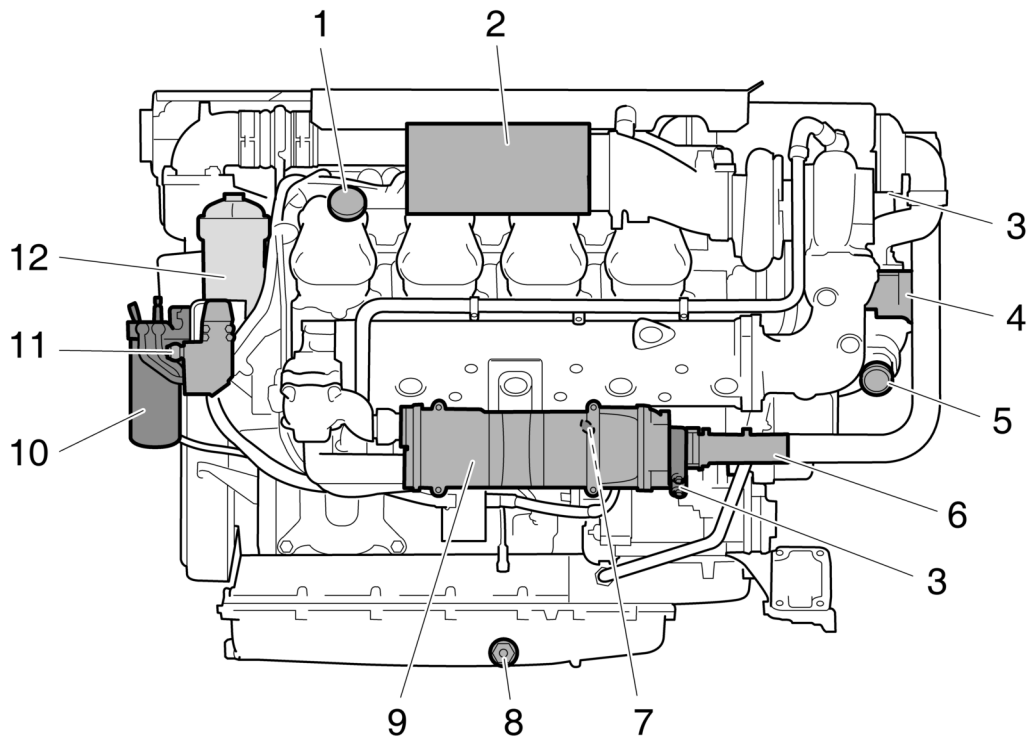

381 636

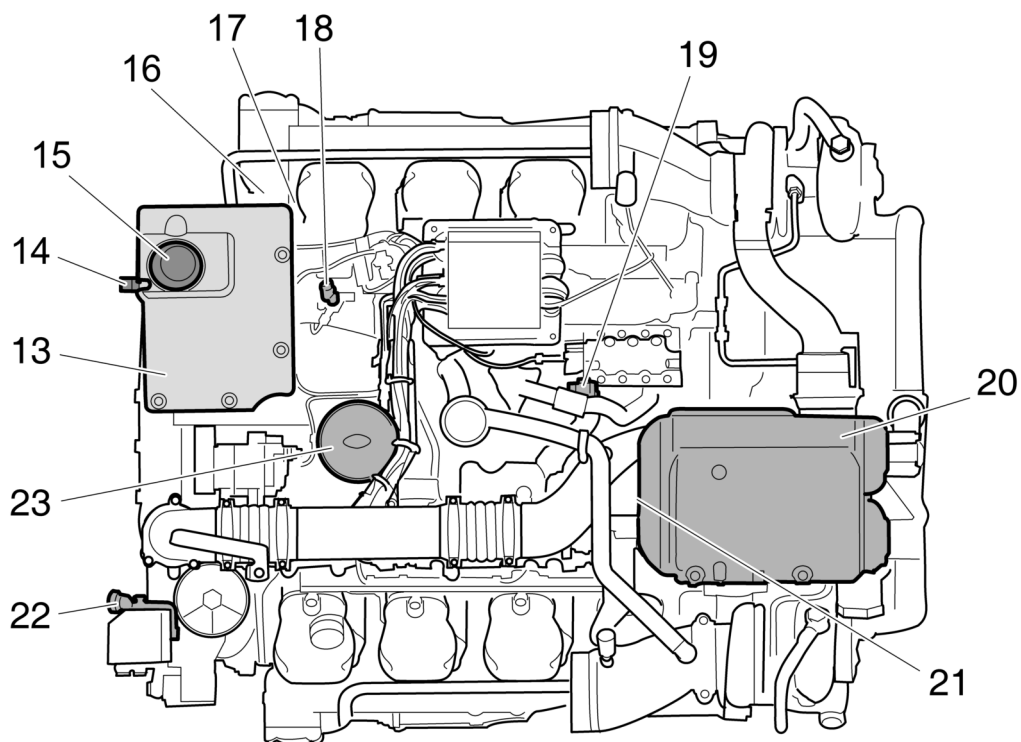

381 637

1. Oil filler.
2. Air filter.
3. Sacrificial anodes (6).
4. Sea water pump.
5. Sea water intake.

6. Sea water outlet (1 on each side)
7. Valve for draining and filling coolant (1 on each side behind the heat exchanger).
8. Oil plug.
9. Heat exchanger (1 on each side).
10. Fuel filter.
11. Hand pump for fuel.
12. Oil filter.
13. Expansion tank.
14. Level glass for checking coolant level.
15. Filling coolant.
16. Engine serial number, stamped into the cylinder block.
17. Engine data plate.
18. Fuel manifold bleed nipple.
19. Bleed nipple on high pressure pump.
20. Charge air cooler.
21. Holes for draining condensation in charge air cooler (2 pcs on the underside).
22. Oil dipstick.
23. Centrifugal oil cleaner.

Note:

The 2 water separating prefilters for the fuel are located between the fuel tank and engine.

Starting and driving

Checks before first start

Before the engine is started for the first time, carry out the maintenance items listed under First start in the maintenance schedule. Check the following (also see Maintenance intervals):

- Oil level.
- Coolant.
- Fuel level.
- Fluid level in batteries.
- Battery state of charge.
- Condition of the drive belt.

checks before driving

Carry out daily maintenance as described in the maintenance schedule prior to operation. See Maintenance intervals.

Starting the engine



WARNING!

Never use starter gas or similar agents to help start the engine. This can cause an explosion in the intake manifold and possible injury.

Only start the engine in a well ventilated area. When the engine is run in an enclosed space, there must be effective devices to extract exhaust gases and crankcase gases.



IMPORTANT!

The starter motor must only be cranked twice for 30 seconds at a time. After that, it must rest for at least 5 minutes before the next attempt to start it.

For environmental reasons the Scania engine has been developed to be started with a low fuel feed. Using unnecessarily large amounts of fuel when starting the engine always results in emissions of unburnt fuel.

1. Open any fuel cock.
2. Disengage the engine.
3. If the engine has a battery master switch:
Switch on the power by means of the battery master switch.
4. Start the motor.

If the fuel tank has been run dry or if the engine has not been used for a long time, bleed the fuel system. Refer to the Bleeding the fuel system section.

Starting at low temperatures

Take the local environmental requirements into account. Use a fuel heater and engine heater to avoid starting problems and white smoke.

Scania recommends that an engine heater should be used if the engine will be used at temperatures below -10°C (14°F).

A low engine speed and a moderate load on a cold engine limits white smoke, gives better combustion and warms up the engine more quickly than warming it up with no load.

Avoid running it longer than necessary at idling speed.

Driving

Check instruments and warning lamps at regular intervals.

Engine speed range

The engine operating speed range is between low idling and the nominal engine speed. The nominal engine speed is indicated on the engine data plate. Low idling can be set between 500 and 1,050 rpm.

Limp home operation

If there is a fault in the normal throttle opening or if CAN communication is interrupted, the following emergency operation option is provided:

A CAN fault or throttle opening fault in an all-speed engine (both signal and idling switch):

- The throttle opening value is 0% and the engine is running at normal idling speed.
- The throttle opening value is 0% and the engine runs at fixed raised idling speed (800 rpm) if this function is activated.

Throttle opening fault, but the idling switch is working:

- The throttle opening value can be increased slowly between 0 and 50% by using the idling switch.

CAN fault:

- The engine is switched off if the shutdown function is activated.

Driving at high altitude

When driving at high altitudes engine power is reduced automatically due to the lower oxygen content in the air. It is then not possible to run the engine at maximum power.

- IFN, Patrol Craft Long and Patrol Craft Short engines must not be used at an altitude of more than 1,000 metres.
- Contact Scania if the operating conditions deviate from these.

Coolant temperature



IMPORTANT!

An excessive coolant temperature can cause engine damage.

Normal coolant temperature during operation is approximately 94°C (200°F).

The alarm levels are set in the engine control unit. The default setting for the lowest and highest limit values for high coolant temperature are 95°C/203°F and 105°C/221°F respectively.

The high coolant temperature alarm has the following functions:

- Alarm only.
- Alarm and torque reduction at the lowest limit value.
- Alarm at the lowest limit value and engine shutdown at the highest limit value.
- Alarm, torque reduction at the lowest limit value and engine shutdown at the highest limit value.
- Alarm at the lowest limit value and engine shutdown at the highest limit value with the possibility of engine shutdown override control.
- Alarm, torque reduction at the lowest limit value and engine shutdown at the highest limit value, with the possibility of engine shutdown override control.

If run for extended periods under an extremely light load, the engine may have difficulty in maintaining the coolant temperature. At an increased load the coolant temperature rises to the normal value.

Oil pressure

Normal oil pressure during operation is 3-6 bar (43.5-87 psi). The lowest permitted oil pressure when idling is 0.7 bar (10.2 psi).

The engine management system issues an alarm at the following levels:

- At an engine speed below 1,000 rpm and an oil pressure below 0.7 bar (10.2 psi).
- At an engine speed above 1,000 rpm and an oil pressure below 2.5 bar (36.3 psi) for longer than 3 seconds.

The incorrect oil pressure alarm has the following functions:

- Alarm only.
- Alarm and torque reduction by 30%.
- Alarm and engine shutdown.
- Alarm and engine shutdown override control.

Note:

High oil pressure (above 6 bar/87 psi) is normal if the engine is cold when started.

Charging indicator lamp

If the lamp comes on during operation: Check and adjust the alternator drive belt according to the instructions in the section Checking the drive belt.

If the charging indicator lamp is still on, this could be due to an alternator fault or a fault in the electrical system.

Belt transmission

When the belt transmission is new, it may make a squeaking noise when running. This noise is normal and disappears after 50-100 hours of operation. The noise does not affect the service life of the belt transmission.

Engine shutdown



IMPORTANT!

There is risk of post boiling and of damage to the turbocharger if the engine is switched off without cooling. The power must not be switched off before the engine has stopped.

Note:

The battery voltage must remain on for a few seconds after the 15 voltage is switched off so that the control units can store the values and switch to standby mode.

10 prohibited engine shutdowns will cause a torque reduction (70% of fuel volume). Reset the engine by switching it off correctly once.

1. Run the engine without a load for a few minutes if it has been run continuously with a heavy load.
2. Switch off the engine.

Checks after driving



WARNING!

Block the starting device when working on the engine. If the engine starts unexpectedly, there is a serious risk of injury.

There is always a risk of sustaining burns when an engine is hot. Particularly hot parts are branch pipes, turbochargers, oil sumps, and hot coolant and oil in pipes and hoses.



IMPORTANT!

Check the coolant level following the first start. Top up with coolant as necessary.

1. Check that the power supply has been cut.
2. Top up the fuel tank. Make sure that the filler cap and the area round the filler opening are clean to avoid contamination of the fuel.
3. If there is a risk of freezing, the cooling system must contain enough glycol. See the section Coolant resistance to cold.
4. If the temperature is below 0°C (32°F): Prepare for the next start by connecting the engine heater (if fitted).

Maintenance

The maintenance programme covers a number of points that are divided into the following sections:

- Lubrication system.
- Air cleaner.
- Cooling system.
- Fuel system.
- Miscellaneous.



WARNING!

Block the starting device when working on the engine. If the engine starts unexpectedly, there is a serious risk of injury.

There is always a risk of sustaining burns when an engine is hot. Particularly hot parts are branch pipes, turbochargers, oil sumps, and hot coolant and oil in pipes and hoses.

The maintenance programme includes the following:

- S maintenance: Minimum basic maintenance.
- M maintenance: More extensive maintenance.
- L maintenance: Almost all maintenance items.
- XL maintenance: All maintenance items.

During a period, the sequence is S-M-S-L-S-M-S-L-S-M-S-XL.

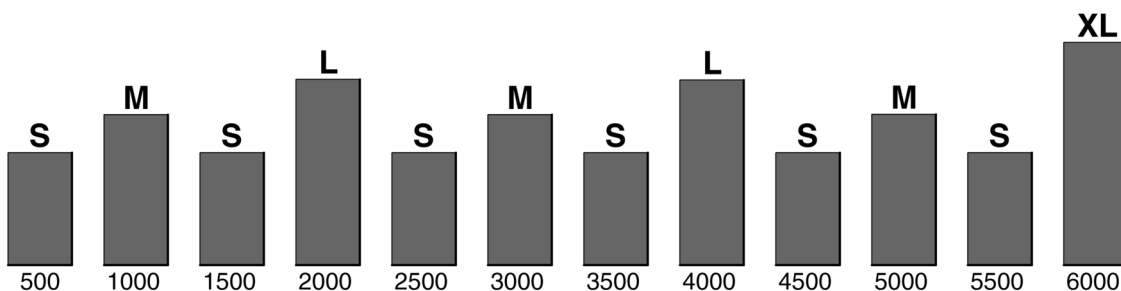

313 153



IMPORTANT!

On delivery a Scania engine is optimised for its application. However, regular maintenance is necessary to:

- prevent unplanned stops
- extend the service life of the engine
- maximise the long-term emission performance of the engine
- give the best possible operating economy.

Maintenance interval

	Daily	First time at		Interval (hours)					Minimum	
		first start	500	500	1,000	2,000	6,000	annual-ly	every 5 years	
			R	S	M	L	XL			
Lubrication system										
Checking the oil level	X	X								
Changing the oil ¹			X	X	X	X	X	X		
Cleaning the centrifugal oil cleaner			X	X	X	X	X	X		
Renewing the oil filter ¹			X	X	X	X	X	X		
Air cleaner										
Reading the vacuum indicator	X		X	X	X	X	X	X		
Renewing the filter element						X	X			X
Renewing the safety cartridge						X	X			X
Renewing an air filter with a non-renewable element						X	X			X
Cooling system										
Checking the coolant level	X	X	X	X	X	X	X	X		
Checking the coolant's anti-freeze and corrosion protection		X				X	X	X		
Checking the sacrificial anodes			X	X	X	X	X	X		
Checking the sea water pump impeller			X	X	X	X	X	X		
Changing the coolant and cleaning the cooling system							X			X
Fuel system										
Checking the fuel level	X	X								
Draining the water separating prefilter			X	X	X	X	X			
Renewing the fuel filters			X	X	X	X	X			X
Other										
Checking the drive belt		X			X	X	X	X		
Checking for leakage	X		X	X	X	X	X			
Checking and adjusting the valve clearance			X			X	X			

1. DI16 304M has a shorter oil change interval; see separate table on the next page.

Oil change interval DI16 304M

The following oil change interval applies for DI16 304M:

	Daily	First time at		Interval (hours)				Minimum every 24 months
		first start	250	500	750	1,000	1,250	
Lubrication system								
Changing the oil			X	X	X	X	X	X
Renewing the oil filter			X	X	X	X	X	X

Lubrication system

Oil grade

Scania LDF stands for the Scania Long Drain Field test standard. Scania LDF oils have been carefully selected after extensive testing. The approval is only granted to the highest grade engine oils available on the market.

Recommended engine oil
Scania Oil LDF-3
Scania Oil LDF-2
Scania Oil LDF
Scania Oil E7

The engine oil must satisfy the following quality requirements:

- ACEA E5/API CI-4.
- ACEA E7/API CI-4 +.
- For engines not run on low-sulphur fuel, the TBN (Total Base Number) should be at least 12 (ASTM D2896).
- Oils with a low ash content (ACEA E9/API CJ4) are not recommended.

Check with your oil supplier that the oil satisfies these requirements.

If the engine is used in areas of the world where engine oil with ACEA or API classification is not available, the oil grade must be measured in actual operation. In this case contact the nearest Scania workshop.

For operation at extremely low outdoor temperatures: Consult your nearest Scania workshop on how to avoid starting difficulties.

Viscosity class	Outdoor temperature		
SAE 20W-30	-15°C (5°F)	-	+30°C (86°F)
SAE 30	-10°C (14°F)	-	+30°C (86°F)
SAE 40	-5°C (23°F)	-	+45°C (113°F)
SAE 50	0°C (32°F)	-	+45°C (113°F)
SAE 5W-30	< -40°C (-40°F)	-	+30°C (86°F)
SAE 10W-30	-25°C (-13°F)	-	+30°C (86°F)
SAE 15W-40	-20°C (-4°F)	-	+45°C (113°F)

Oil grade labels

When changing oil it is important to use the correct engine oil grade. The oil filler cap must therefore be clearly marked with a label for the oil grade that is required.

If the label is missing or if the engine oil grade is changed, a new label must be fitted.

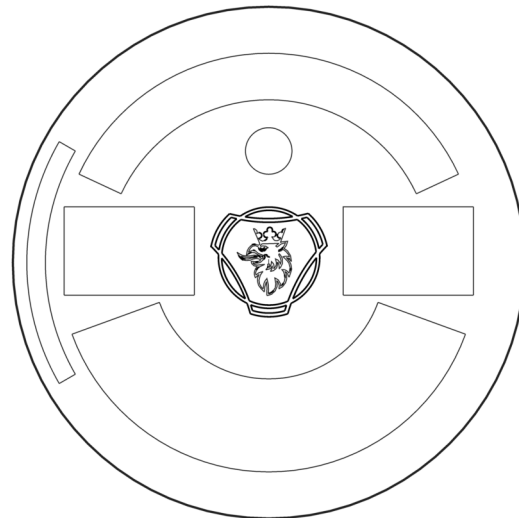

353 114

Oil filler labels.

Parts

Oil grade	Colour	Part number
Scania LDF-3	Red	2 296 066
Scania LDF-2	Blue	2 296 064
Scania LDF	Grey	2 296 071
ACEA E7	White	2 296 065
Scania Low Ash	Green	2 296 067
Scania Bioethanol	Black	2 296 068
Scania BEO-2	Orange	2 296 070
ACEA E9	-	2 296 069

Oil analysis

To extend the oil change intervals using oil analysis, Scania LDF-2 and LDF-3 oils must be used. Most oil companies offer analysis of the engine oil.

The following requirements must remain satisfied when the oil is changed:

- Viscosity at 100°C (212°F): max. $\pm 20\%$ of original value of the fresh oil.
- TBN (in accordance with ASTM D4739): > 3.5.
- TBN (in accordance with ASTM D4739): > TAN (in accordance with ASTM D664).
- Soot (in accordance with DIN 51452): < 3%.
- Fuel in the oil: < 5%.

Such analysis measures the oil's TBN (Total Base Number), TAN (Total Acid Number), fuel dilution, water content, viscosity and the quantity of particles and soot in the oil. A suitable oil change interval will be established following a series of oil analyses.

If the conditions are changed, a new series of oil analyses must be carried out to establish new oil change intervals.



REQUIREMENT!

Depending on the market, the warranty conditions may also change if the oil change intervals differ from the recommended Scania timetable.

Checking the oil level



REQUIREMENT!

Leave the engine off for at least 7 minutes before you check the oil level.

If the oil level exceeds the maximum level, the oil must be changed. Check the cause if the oil level exceeds the maximum level and contact your nearest workshop with qualified personnel if you suspect a fault.

1. Pull out the oil dipstick and check the oil level. The correct level is between the minimum and maximum marks on the oil dipstick.
2. Fill with more oil via the oil filler if the oil level is at or below the minimum mark.

For information on the correct oil type, see the section [Oil grade](#).

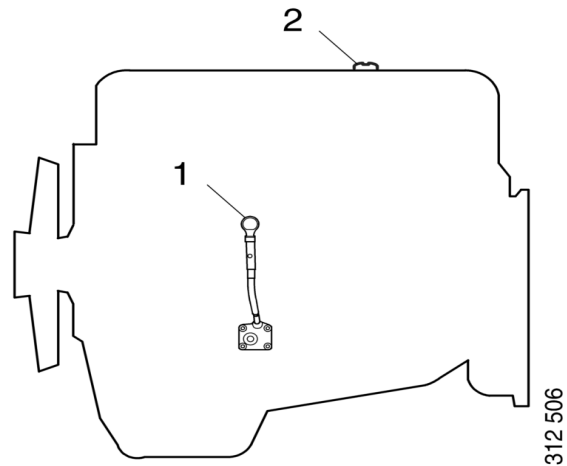

Changing the oil



WARNING!

Hot oil can cause burns and skin irritation. Wear protective gloves and eye protection when changing hot oil. Make sure that there is no pressure in the lubrication system before changing the oil. The oil filler cap must always be in place when starting and driving the engine to prevent oil being ejected.

Note:

Change oil more often if the engine is subjected to particularly demanding operation, such as a dusty environment, or if deposits in the centrifugal oil cleaner are thicker than 28 mm (1.1 in).

Renew the oil filter and clean the centrifugal oil cleaner when changing oil.



Environment

Use a suitable container. Used oil must be disposed of as specified in national and international laws and regulations.

1. Unscrew the oil plug and drain the oil when the engine is hot. In certain engine types the oil is pumped out by means of a bilge pump. If the engine is drained via the valve, the oil should be hot. Alternatively, use a pump. This is so that draining occurs more quickly.
2. Wipe off the magnet on the oil plug.
3. Renew the gasket on the oil plug.
4. Refit the oil plug.
5. Fill with the amount of oil specified for the oil sump.
6. Wait at least 7 minutes.
7. Check the level on the oil dipstick.

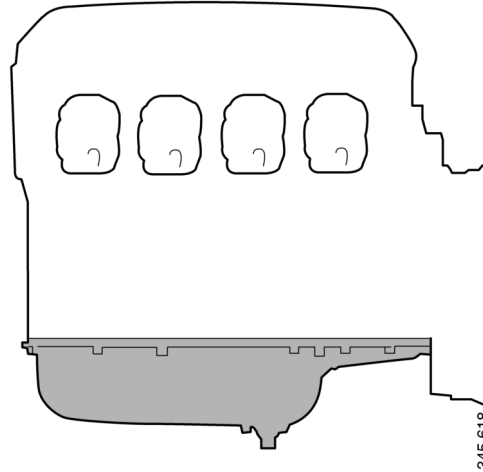

Oil volume for oil sump with deep front:

Min. 40 litres (10.5 US gallons).

Max. 48 litres (12.6 US gallons).

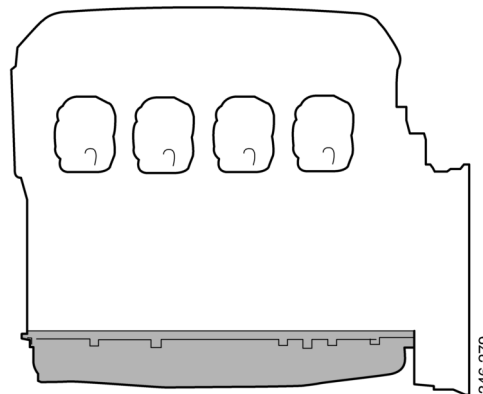

Oil capacity for low oil sump:

Min. 29 litres (7.6 US gallons).

Max. 37 litres (9.7 US gallons).

Maximum angles of inclination during operation

Maximum permissible angles of inclination during operation vary, depending on the type of oil sump. See illustration.

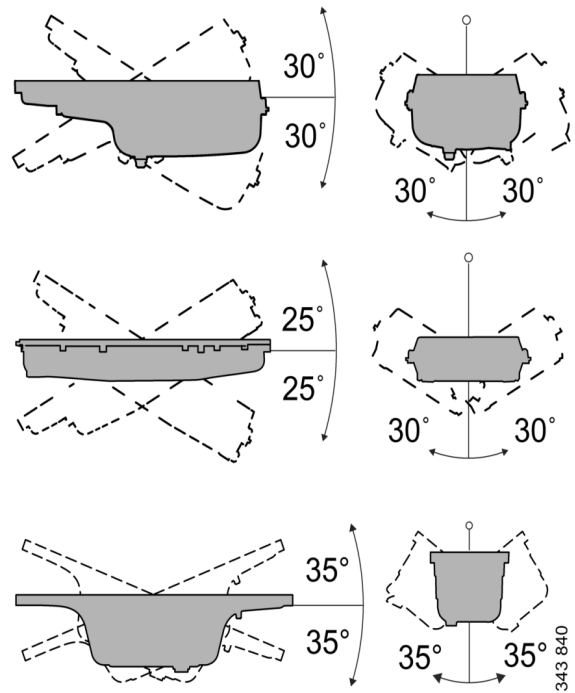

Cleaning the centrifugal oil cleaner



WARNING!

The oil may be hot. Carefully remove the cover from the centrifugal oil cleaner.

Wear eye protection and protective gloves when working on the centrifugal oil cleaner.

When the centrifugal oil cleaner is cleaned, there should be some dirt deposits on the paper in the rotor cover. If the paper is clean, the equipment is not working as it should. If this is the case, investigate the cause of this.

Renew the paper more frequently if the dirt deposits are thicker than 28 mm (1.1 inches) during a scheduled oil change.

1. Clean the cover.
2. Unscrew the nut securing the outer cover.
3. Let the oil run out from the rotor.
4. Lift out the rotor. Wipe off the outside.
5. Loosen the rotor nut and unscrew it about 1.5 turns.

Note:

Take care not to damage the rotor shaft.

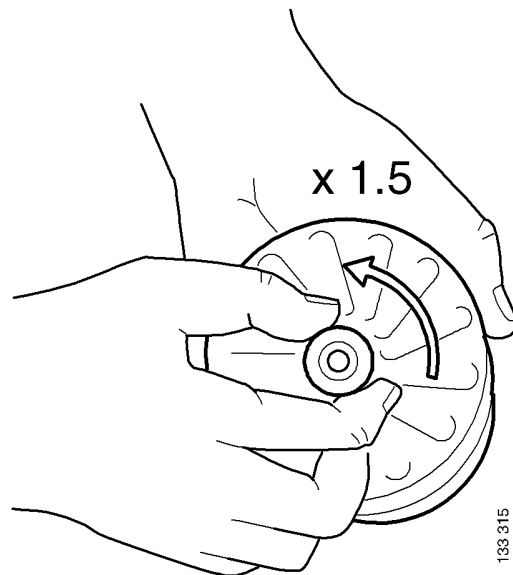

6. If the rotor nut is jammed: Turn the rotor upside down and fasten the rotor nut in a vice. See illustration.
7. Use protective jaws so as not to damage the grooves of the rotor nut.
8. Turn the rotor 1.5 turns anti-clockwise by hand.
9. If this does not work: Screw 2 nuts together with an M20 screw.
10. Position the screw head at the bottom of the rotor.
11. Position a ring spanner on the lower nut and turn the rotor 1.5 turns anti-clockwise.

! IMPORTANT!

Do not attach the rotor directly to the vice. Never strike the rotor cover.

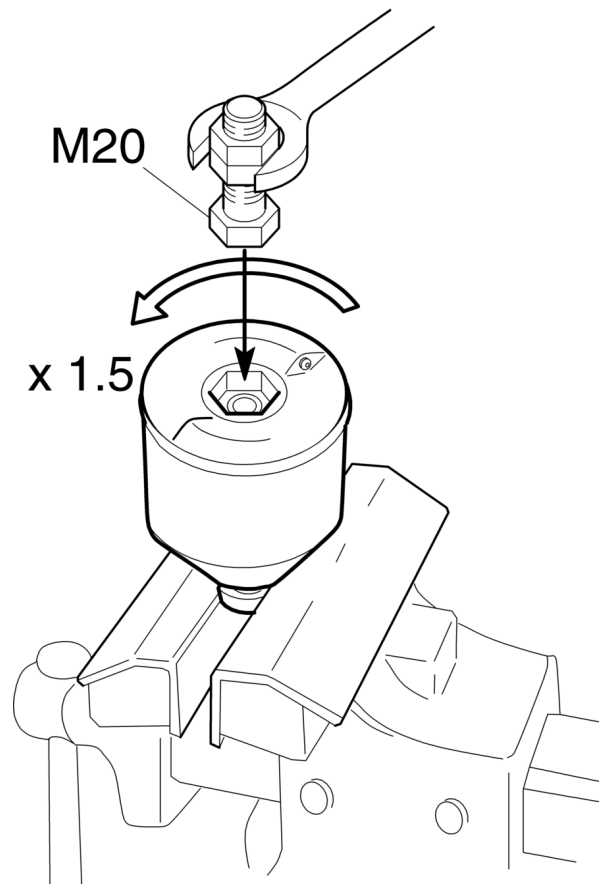

12. Remove the rotor cover by holding the rotor in both hands and tapping the rotor nut against the table. Never strike the rotor directly as this may damage its bearings.
13. Remove the strainer from the rotor cover. If the strainer is stuck, insert a screwdriver between the rotor cover and strainer and carefully prise them apart.

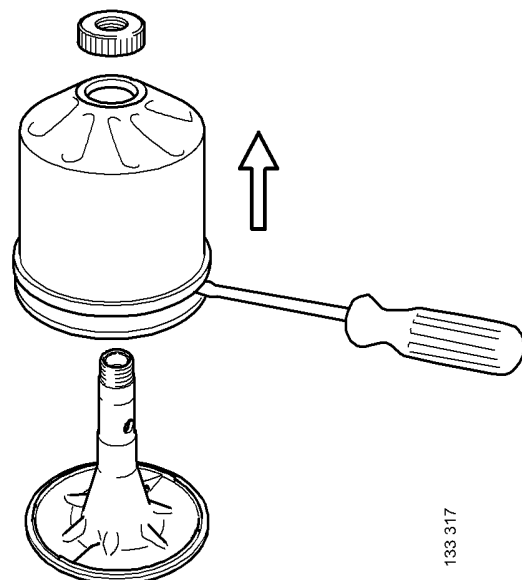

133 317

14. Remove the paper insert.
15. Scrape off any remaining dirt deposits from the inside of the rotor cover. If the deposits on the paper are thicker than 28 mm (1.1 in), the centrifugal oil cleaner must be cleaned more often.

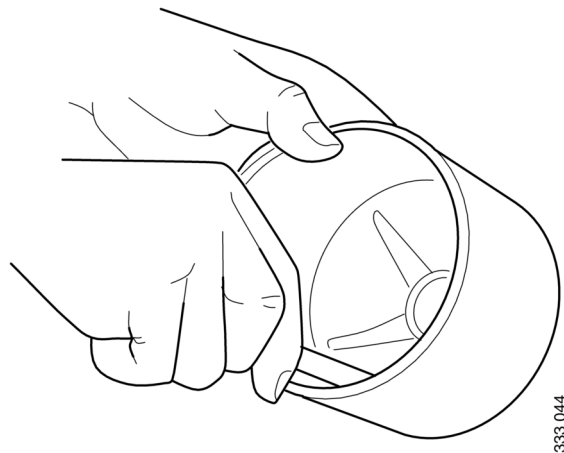

333 044

16. Wash the parts according to the applicable industrial method.
17. Check the 2 nozzles on the rotor. Ensure that they are not blocked or damaged.
Renew any damaged nozzles.
18. Check that the bearings are undamaged.
Renew damaged bearings.

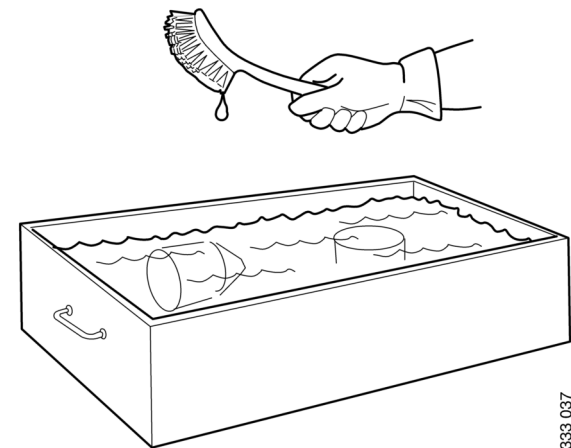

333 037

19. Fold and fit a new paper insert on the inside of the rotor cover as illustrated.

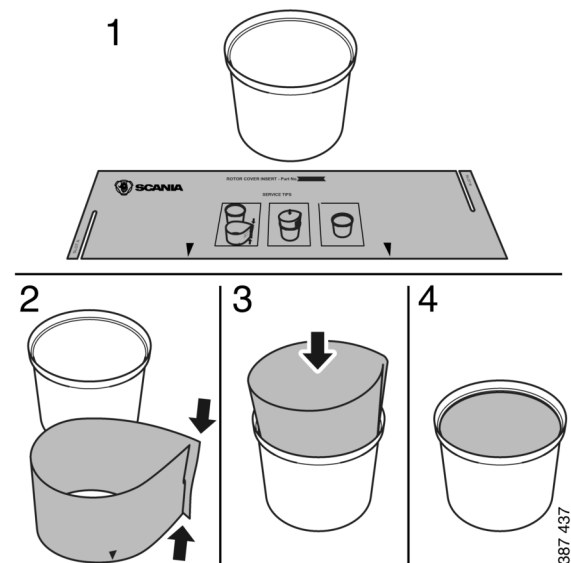

387 437

20. Fit the strainer onto the rotor.
21. Fit a new O-ring to the foot of the centrifugal oil cleaner.
22. Refit the rotor cover. Ensure that the O-ring is not outside the edges, but is in the groove.
23. Screw the rotor nut back on by hand.
24. Check that the shaft is not damaged or loose.
Contact a workshop with qualified personnel if the rotor shaft needs to be renewed.

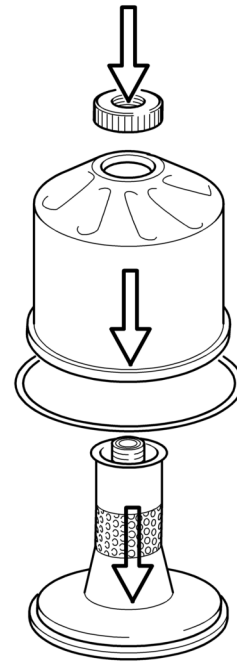

Note:

Take care not to damage the rotor shaft.

25. Refit the rotor and rotate it by hand to make sure it rotates easily.

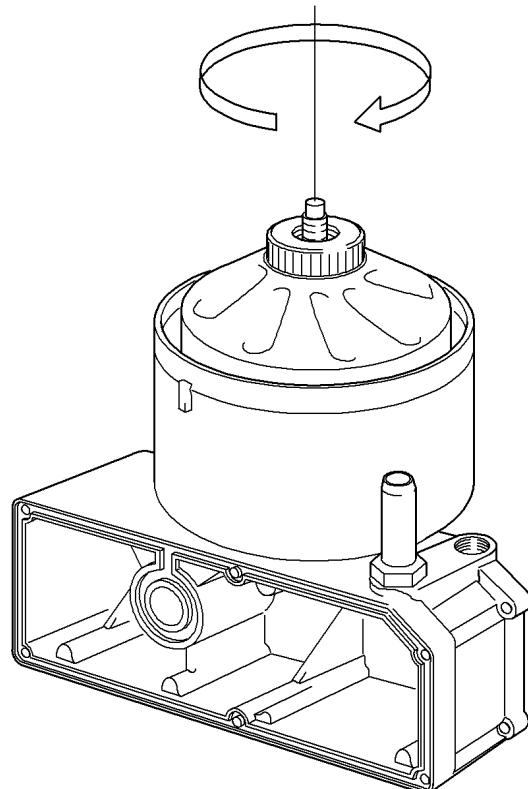

127 882

26. Fit a new O-ring in the cover.
27. Refit the cover and tighten the lock nut.
Tightening torque 20 Nm (15 lb-ft).

! **IMPORTANT!**

To reduce the risk of oil leakage it is important to tighten the cover to the correct tightening torque.

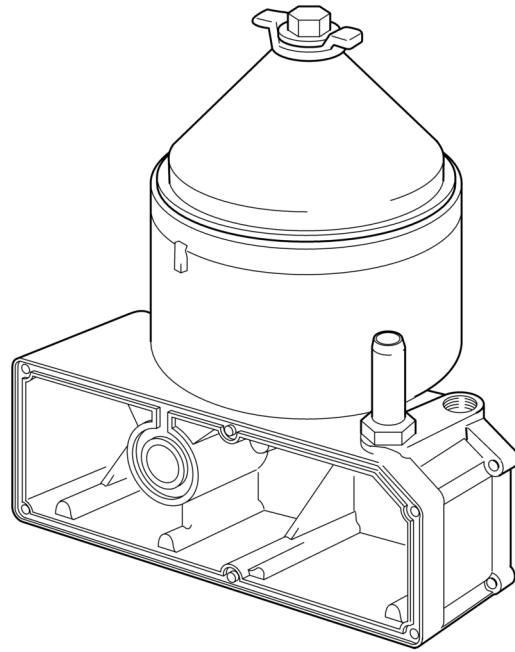

333 043

Operational testing of the centrifugal oil cleaner

Operational testing need only be carried out if it is suspected that the centrifugal oil cleaner is malfunctioning. For example, if there are unusually few deposits given the distance driven.

1. Run the engine until it reaches normal operating temperature.
2. Stop the engine and listen for noise coming from the rotor. It should continue rotating for a time, even when the engine has stopped.
3. Use your hand to feel if the filter housing is vibrating.
4. If the filter housing is not vibrating, dismantle and check the centrifugal oil cleaner.

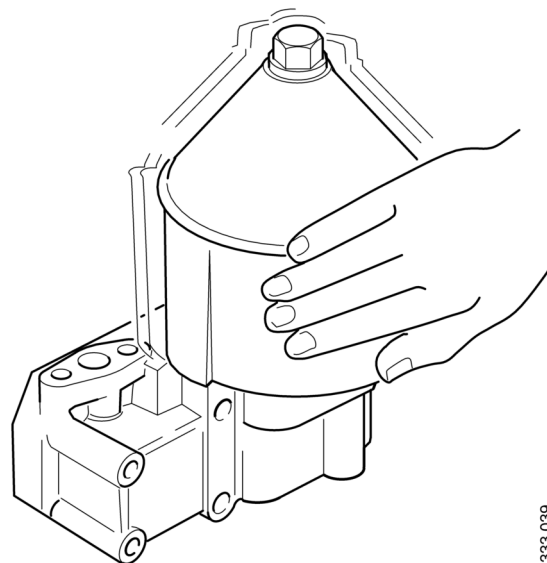

333 039

Renewing the oil filter

Tool

Designation	Figure
Hexagon socket, 1/2", 36 mm	



IMPORTANT!

Clean the centrifugal oil cleaner at the same time as you change the oil filter. Otherwise, the oil filter will become blocked and the resistance in the filter will increase. If this happens, an overflow valve in the filter retainer opens and lets the oil pass without being filtered.

The engine must not be run without a filter element in the oil filter. There is a risk of engine damage caused by particles and by the oil pressure being too low.

1. Unscrew the filter cover using the socket.



IMPORTANT!

Do not use an adjustable spanner or other open tool, as there is a risk of damaging the filter cover.

2. Lift out the filter housing cover with filter element. The filter housing will drain automatically once the filter has been removed.
3. Undo the old filter from the cover by carefully bending it to one side.
4. Fit a new O-ring on the cover. Lubricate the O-ring with engine oil.
5. Press a new filter into the snap fastener in the cover and tighten the filter cover to 25 Nm (18 lb/ft).
6. Make sure the oil filter drain has emptied the oil from the filter housing. Screw on the filter cover firmly with the socket.
7. Start the engine and inspect the filter housing for leaks.

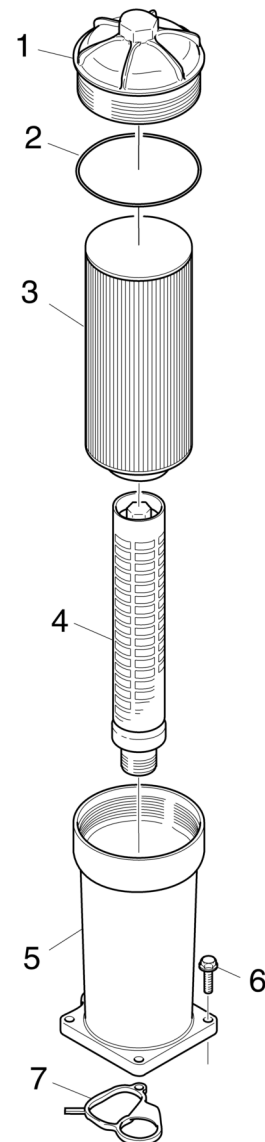

1. Cover.
2. O-ring.
3. Filter element.
4. Pipe.
5. Filter housing.
6. Flange screw.
7. Gasket.

381 921

Air cleaner

Reading the vacuum indicator

If the indicator's red piston is fully visible, renew the air cleaner filter element following the instructions below.

Renewing the filter element



WARNING!

Never start the engine without the air filter in position. If you do this, you risk personal injury and major engine damage.



IMPORTANT!

Renew the filter element earlier than the maintenance interval if the indicator shows red.

There is always a risk that the filter element will be damaged when it is cleaned.

The filter element must not be cleaned in water or be blown clean with compressed air.

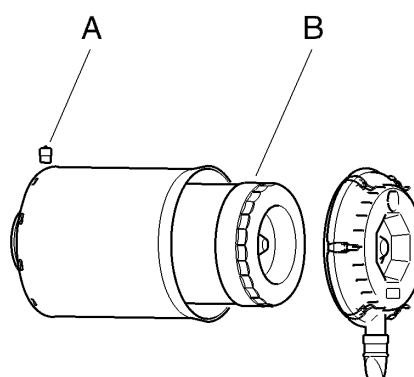

336 100

1. Remove the cover from the air cleaner.
2. Renew the filter element.
3. Insert an inspection lamp into the element and check from the outside that there are no holes or cracks in the filter paper.
4. Assemble the air cleaner.
5. Reset the vacuum indicator by pressing in the button.

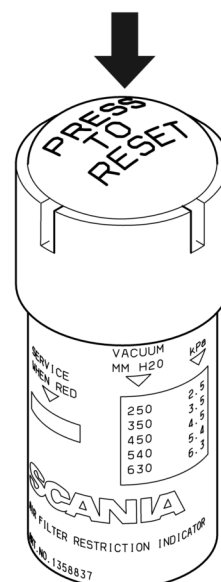

326 671

Renewing the safety cartridge



WARNING!

Never start the engine without the air filter in position. If you do this, you risk personal injury and major engine damage.



IMPORTANT!

When you renew the safety cartridge, take great care to ensure that no dirt or other impurities get into the engine. Do not remove the safety cartridge unnecessarily.

1. Remove the cover from the air cleaner.
2. Remove the filter element.
3. Remove the safety cartridge.
4. Fit a new safety cartridge from Scania.
5. Renew or clean the filter element.
6. Check the condition of the O-ring. Renew the O-ring if it is damaged or hard.
7. Assemble the air cleaner. Ensure that the O-ring is not outside the edges.

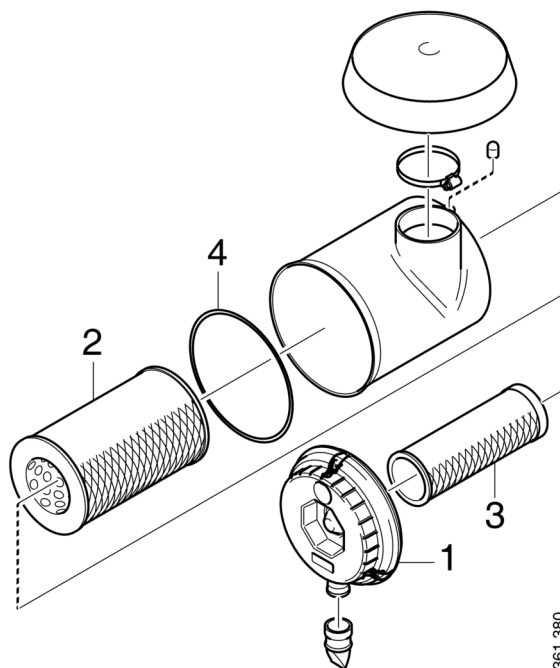

361 380

Renewing an air filter with a non-renewable element



IMPORTANT!

If the engine has air filters with a non-renewable Scania element, they should be renewed instead of cleaned.

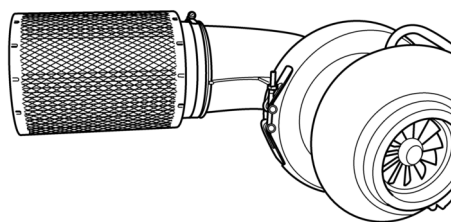

325 166

Air filter with a non-renewable element.

Cooling system

Coolant

Only Scania coolant or other products that Scania has tested to provide proper antifreeze and corrosion protection, may be used in Scania engines.

Products that do not satisfy the requirements for use in a Scania engine can result in faults in and damage to the cooling system. This can lead to the invalidation of Scania's warranty for faults and damage caused by the use of inappropriate coolant.



WARNING!

Ethylene glycol can be fatal if ingested and can cause skin irritation and eye damage.

Note:

The coolant should be changed when the cooling system is cleaned: every 6,000 hours or at least every 5 years. See the section [Changing the coolant and cleaning the cooling system](#).

The coolant has several properties which are important for the function of the cooling system:

- Corrosion protection.
- Antifreeze.
- Increases the boiling point.

Scania recommends that the coolant used is a mixture of water with antifreeze and corrosion protection (ethylene glycol). The coolant should always contain 35-55% antifreeze and corrosion protection by volume so that the coolant has the correct properties for the cooling system to work.

Coolant resistance to cold

The following example shows coolant properties with 30% by volume of antifreeze and corrosion protection:

- Ice slush starts to form at -16°C (3°F).
- At -30°C (-22°F), there is a risk of disruptions in the cooling system.
- There is no risk of damage by freezing with a minimum antifreeze and corrosion protection content of 35% by volume.

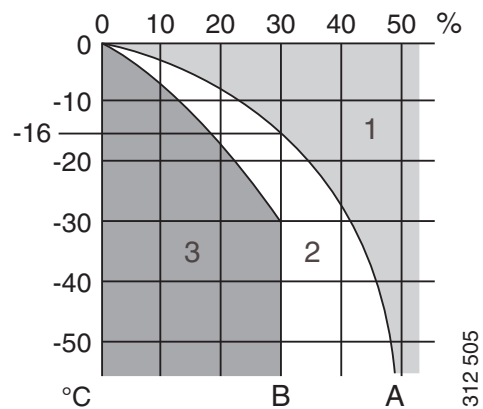

The chart depicts coolant properties at different percentages of antifreeze and corrosion protection concentration by volume.

Curve A: Ice formation starts (ice slush)

Curve B: Damage by freezing occurs

Zone 1: Safe zone

Zone 2: Disruptions may occur (ice slush)

Zone 3: Risk of damage by freezing

Antifreeze and corrosion protection concentration table, litres

35% by volume of Scania antifreeze provides sufficient corrosion protection.

Example:

- The total volume of the cooling system is 40 litres.
- The measured concentration of ethylene glycol is 35% by volume (freezing point -21°C). According to the table there are 14 litres of ethylene glycol in the cooling system.
- The required concentration of ethylene glycol is 45 per cent by volume (freezing point -30°C). According to the table, 18 litres of ethylene glycol are required in the cooling system.
- Since there are already 14 litres in the cooling system, 4 litres of ethylene glycol must be added to the cooling system ($18 - 14 = 4$ litres).

	Adequate corrosion protection					Cooling system volume (litres)
Volume of ethylene glycol (%)	35	40	45	50	60	
Ice slush forms ($^{\circ}\text{C}$)	-21	-24	-30	-38	-50	
Volume of ethylene glycol (litres)	11	12	14	15	18	30
	14	16	18	20	24	40
	18	20	23	25	30	50
	21	24	27	30	36	60
	25	28	32	35	42	70
	28	32	36	40	48	80
	32	36	41	45	54	90
	35	40	45	50	60	100
	39	44	50	55	66	110
	42	48	54	60	72	120
	46	52	59	65	78	130
	49	56	63	70	84	140
	53	60	68	75	90	150
	56	64	72	80	96	160
	60	68	77	85	102	170
	63	72	81	90	108	180
67	76	86	95	114	190	
70	80	90	100	120	200	

Antifreeze and corrosion protection concentration table, US gallons

35% by volume of antifreeze provides sufficient corrosion protection.

Example:

- The total volume of the cooling system is 10.6 US gallons.
- The measured concentration of ethylene glycol is 35% by volume (freezing point -6°F). According to the table there are 3.7 US gallons of ethylene glycol in the cooling system.
- The required concentration of ethylene glycol is 45 per cent by volume (freezing point -22°F). According to the table, 4.8 US gallons of ethylene glycol are required in the cooling system.
- Since the cooling system already contains 3.7 US gallons, fill another 1.1 US gallons of ethylene glycol in the cooling system ($4.8 - 3.7 = 1.1$ US gallons).

	Adequate corrosion protection					Cooling system volume (US gallons)
Volume of ethylene glycol (%)	35	40	45	50	60	
Ice slush forms ($^{\circ}\text{F}$)	-6	-11	-22	-36	-58	
Volume of ethylene glycol (US gallons)	2.9	3.2	3.7	4	4.8	7.9
	3.7	4.2	4.8	5.3	6.3	10.6
	4.8	5.3	6.1	6.6	7.9	13.2
	5.5	6.3	7.1	7.9	9.5	15.9
	6.6	7.4	8.5	9.2	11.1	18.5
	7.4	8.5	9.5	10.6	12.7	21.1
	8.5	9.5	10.8	11.9	14.3	23.8
	9.2	10.6	11.9	13.2	15.9	26.4
	10.3	11.6	13.2	14.5	17.4	29.1
	11.1	12.7	14.3	15.9	19	31.7
	12.2	13.7	15.6	17.2	20.6	34.3
	12.9	14.8	16.6	18.5	22.2	37
	14	15.9	18	19.8	23.8	39.6
	14.8	16.9	19	21.1	25.4	42.3
	15.9	18	20.3	22.5	26.9	44.9
	16.6	19	21.4	23.8	28.5	47.6
17.7	20.1	22.7	25.1	30.1	50.2	
18.5	21.1	23.8	26.4	31.7	52.8	

Antifreeze and corrosion protection products

The antifreeze and corrosion protection products used in Scania engines should be of the ethylene glycol type.

Below is a list of Scania antifreeze and corrosion protection products.

Scania concentrate

Coolant with antifreeze and corrosion protection in the form of a concentrate.

Part no.	Volume litres	Volume US gallons
1 894 323	5	1.3
1 894 324	20	5.3
1 894 325	210	55
18 94 326	1,000	264

Scania Ready Mix

Coolant with antifreeze and corrosion protection Ready Mix 50/50.

Part no.	Volume litres	Volume US gallons
1 921 955	5	1.3
1 921 956	20	5.3
1 921 957	210	55
1 896 695	1,000	264

Checking the coolant level



WARNING!

Do not open the coolant filler cap in the expansion tank if the engine is hot. Hot coolant and steam may spray out and cause burns.

If the cap has to be opened do it slowly to release the pressure before removing the cap. Wear protective gloves as the coolant is still very hot.



IMPORTANT!

It is not permissible to top up large amounts of coolant via the expansion tank. Filling via the expansion tank leads to air locks in the cooling system which can lead to e.g. cavitation damage to the coolant pump shaft seal. If a large amount of coolant needs to be added, follow the instructions in the section [Filling coolant](#).

Only pour pre-mixed coolant into the cooling system.

1. Check the coolant level through the sight glass on the expansion tank.
2. Top up with coolant as necessary.

Checking the coolant's anti-freeze and corrosion protection

Tool

Designation	Illustration
Refractometer	



IMPORTANT!

Use only pure fresh water that is free from particles, sludge and other impurities.

1. Pour a small amount of coolant into a container and check that the coolant is pure and clear.
2. Change the coolant if it is contaminated or cloudy.
3. Measure the antifreeze content with a refractometer.

The following rules apply to ethylene glycol-based coolant:

- The antifreeze and corrosion protection content must be a minimum of 35 per cent by volume for corrosion protection to be sufficient.
- An antifreeze and corrosion protection content greater than 55 per cent by volume impairs the ability to protect from frost.
- If ice forms in the coolant, there are disruptions initially, but there is no immediate risk of damage. The engine should not be subjected to heavy loads when ice starts to form.

Checking the sacrificial anodes

! IMPORTANT!

Corrosion of sacrificial anodes depends on the operating environment. Therefore, check the sacrificial anodes every third month during the first year of commissioning or when changing the operating environment.

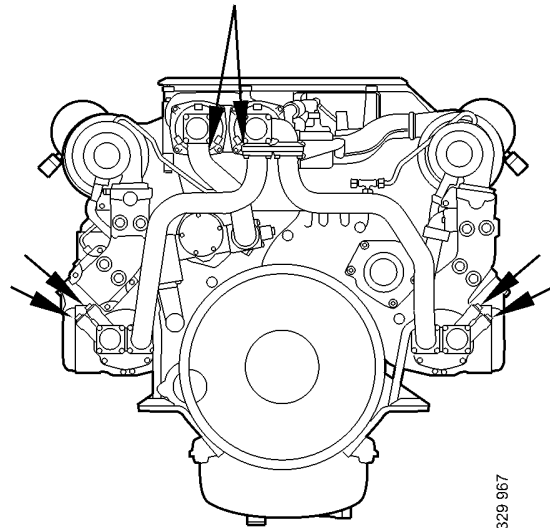

Position of sacrificial anodes.

1. Drain the sea water circuit as described in the [Draining the sea water circuit](#) section.
2. Remove all sacrificial anodes.

3. Check all sacrificial anodes:

- Scrape off all loose material and check the corrosion.
- Renew all sacrificial anodes if there is less than $\frac{3}{4}$ (2) remaining of any of the sacrificial anodes.
- If the sacrificial anodes are very corroded (3), the length of the intervals for checking the sacrificial anodes should be halved. If the sacrificial anodes are very corroded, they often come loose entirely.

4. Renew the gasket when fitting.

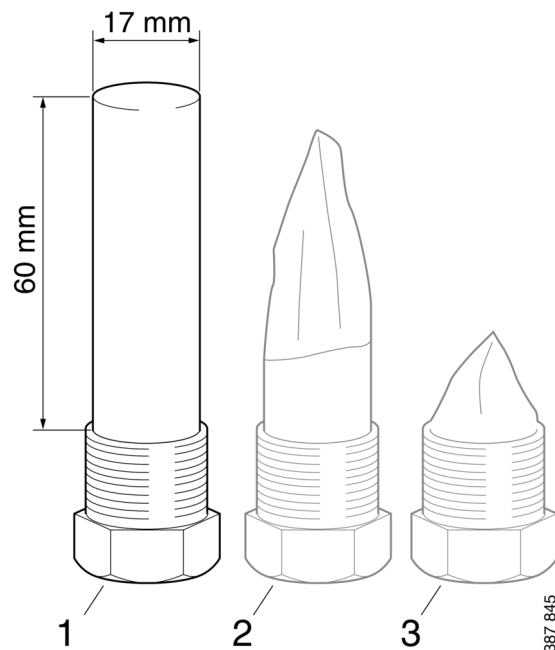

1. New sacrificial anode.

2. Approx. $\frac{3}{4}$ remains.

3. Approx. $\frac{1}{4}$ remains

Checking the sea water pump impeller

1. Drain the sea water circuit. See the section [Draining the sea water circuit](#).
2. Check that the vanes of the impeller are not heavily splintered or damaged.

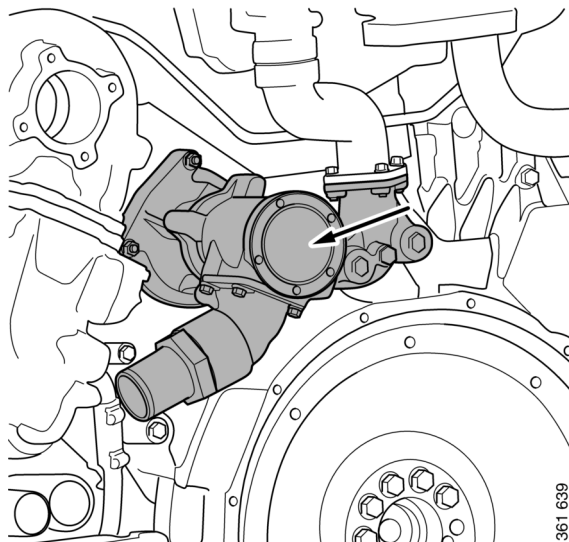

Sea water pump cover.

361 639

Renewing the sea water pump impeller

Special tools

Number	Designation	Illustration
2 443 680	Puller	

Note:

If the impeller must be renewed frequently, the cleaning of the sea water needs to be improved.

There should be a spare impeller on board.

The impeller can be deformed during extended periods of inactivity. Renew the impeller before starting or remove the impeller before longer periods of stoppage.

1. Thread the puller stud into the rubber impeller using an internal hexagon key until the stud reaches the bottom.

Note:

Note the direction of rotation of the impeller vanes.

2. Screw the puller into the rubber impeller using the handle until it reaches the stud. Then continue to screw until the impeller comes loose.
3. Unscrew the stud.



IMPORTANT!

Check that the direction of rotation of the impeller vanes is the same as during removal.

4. Lubricate the impeller with pump grease and then fit it using a rubber mallet.
5. Fit the sea water pump cover. Tightening torque 7.5 Nm (5.5 lb-ft).

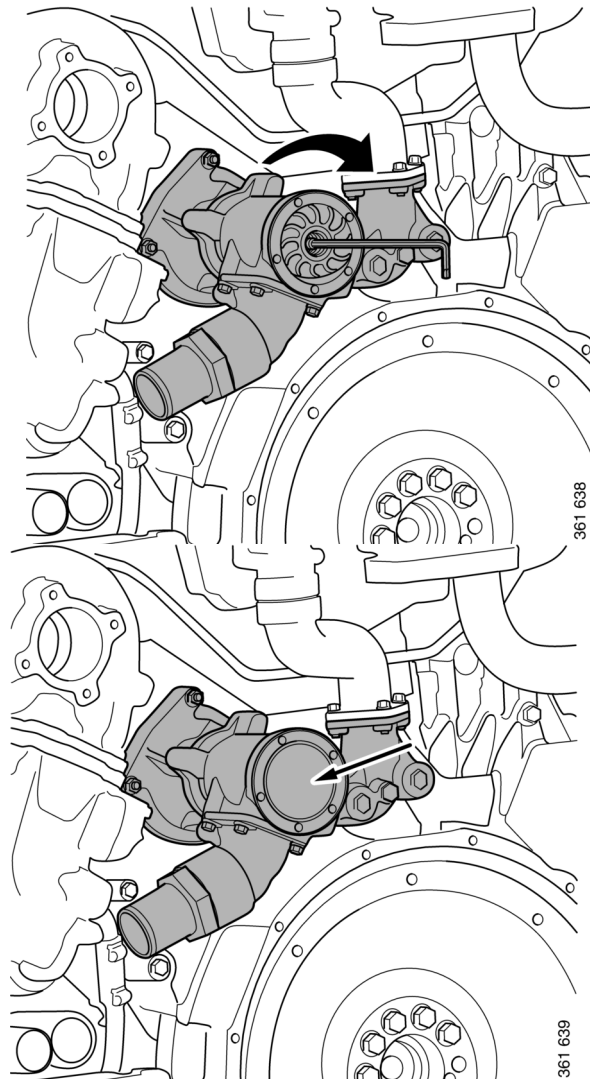

Sea water pump cover.

Changing the coolant and cleaning the cooling system

Draining coolant

Special tools

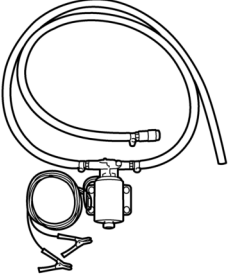
Number, designation	
2 443 679, coolant pump	 <p style="text-align: right; font-size: small;">360 625</p>



WARNING!

Do not open the coolant filler cap in the expansion tank if the engine is hot. Hot coolant and steam may spray out and cause burns. If the cap has to be opened do it slowly to release the pressure before removing the cap.

Use protective gloves as coolant can cause irritation if it comes in contact with the skin. Hot coolant can also cause scalding.



Environment

Use a suitable container. Used coolant must be disposed of as specified in national and international laws and regulations.

1. Open the expansion tank cap.
2. Place the hose from the coolant pump in an empty container.
3. Connect the pump to the draining nipple in the cylinder block. See illustration.
4. Connect the pump's 2 cable terminals to the battery's negative and positive terminal. Make sure that the drainage starts. If the drainage does not start: Change the position of the cable terminals.
5. Repeat the procedure at the cooling system's lowest drainage point. The location of the lowest drainage point on the engine may differ depending on engine application.

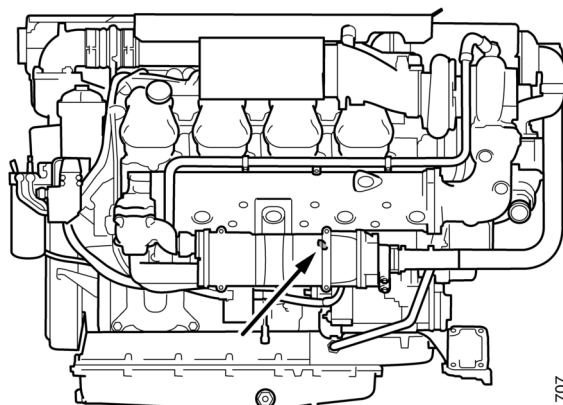

Drain nipple in the cylinder block (behind the heat exchanger).

Draining the sea water circuit

1. Close the bottom valve on the sea water inlet and remove the connection pipe on the outlet from heat exchanger (1).
2. Remove the cover from the sea water pump to completely drain the pump (2).

The lowest point in the sea water circuit may be at different points, but it is usually in the sea water pump intake (3).



IMPORTANT!

Plug the connections to prevent dirt ingress into the engine.

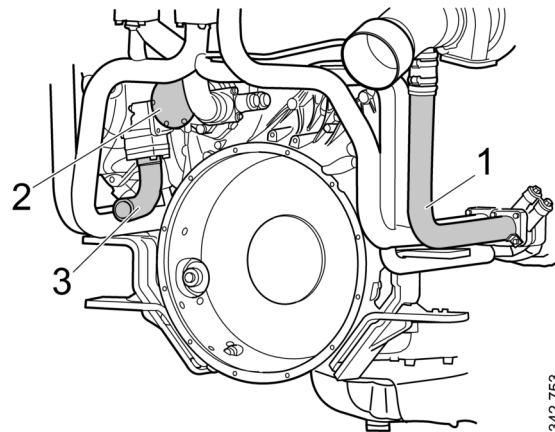

Removing the charge air cooler

When the charge air cooler core needs cleaning, the charge air cooler must be removed if there is no space behind it to take out the core.

1. Make sure that the cooling system is completely drained as described in the previous section.
2. Unscrew and remove the catwalk, protective plate and the protective casing.

3. On the left-hand turbocharger, remove the hose between the oil mist separator and the air filter flange. Use a screwdriver to pull out the lock.

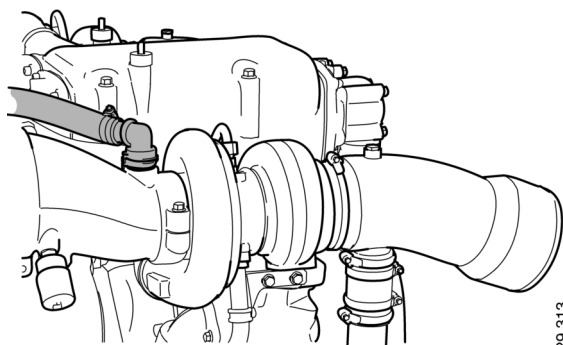

4. Loosen and remove the hose clamps for the charge air pipe.

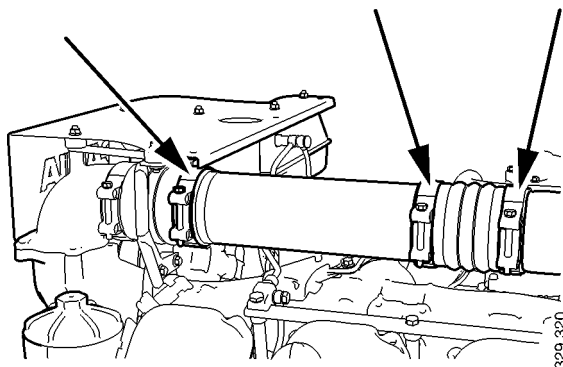

5. Remove all sea water pipes to and from the charge air cooler.

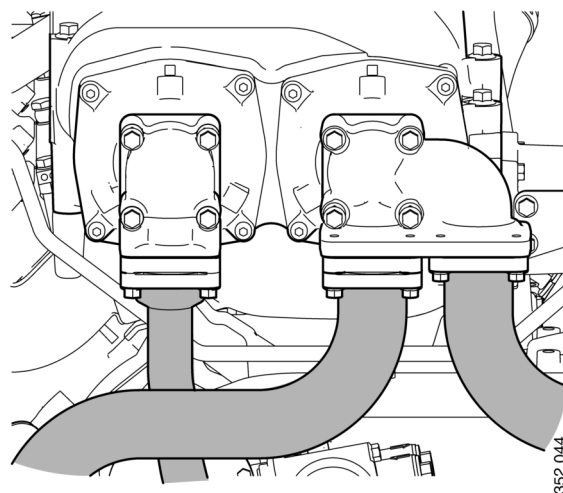

6. Right-hand turbocharger: Remove the V-clamp and the screw for the bracket. Remove the charge air pipe.
7. Left-hand turbocharger: Remove the V-clamp and carefully turn the charge air pipe during removal.

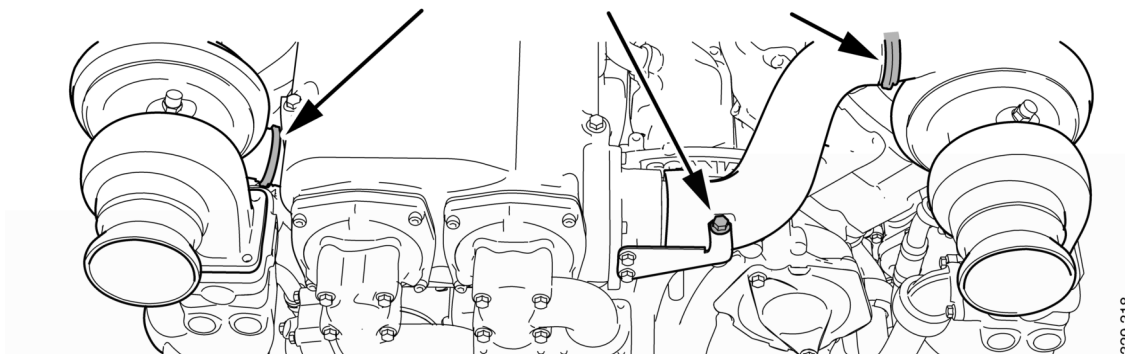

8. Remove the screws securing the charge air cooler.

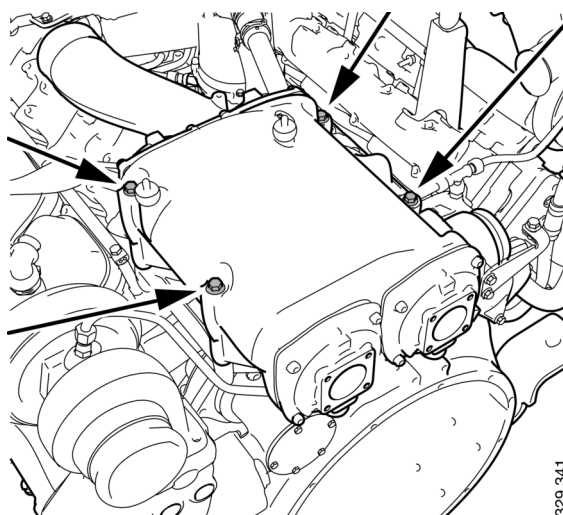

9. Lift out the charge air cooler.

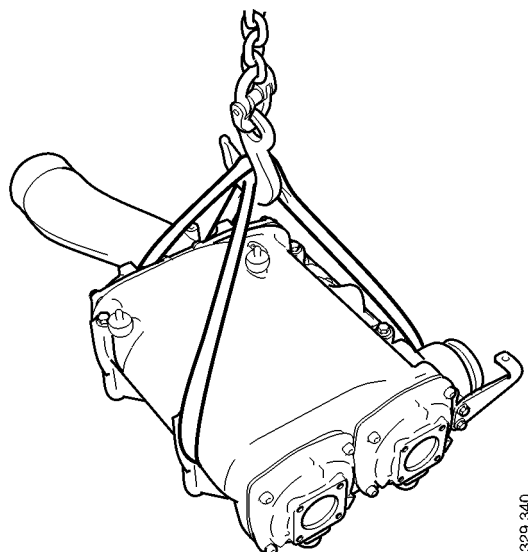

Cleaning the charge air cooler

The charge air cooler must be removed if there is no space behind it to take out the cooler cores. See previous section.

1. Remove the sea water pipes to and from the charge air cooler. Remove flanges and charge air pipe from the charge air cooler. Remove the old gaskets and scrape off any gasket residue.

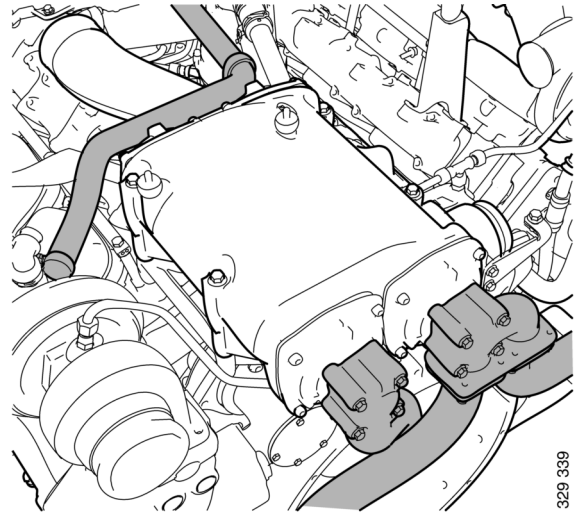

329 339

2. Remove the screws on the charge air cooler covers (1) and remove the covers. Mark the covers so that you can put them back on the correct side.
3. Press in the cooler core (5) slightly on one side and pull it out from the other side.
4. Clean the cooler core on the outside with a slightly acidic detergent, e.g. 2 479 017. Renew the cooler core if it is damaged.



IMPORTANT!

Do not use caustic soda as this could damage the aluminium.

5. Remove any internal deposits in the charge air cooler housing using a round rod.
6. Renew the O-rings (2) and assemble the charge air cooler.
7. Tighten the M8 screws on the cover to 15 Nm (11 lb-ft).

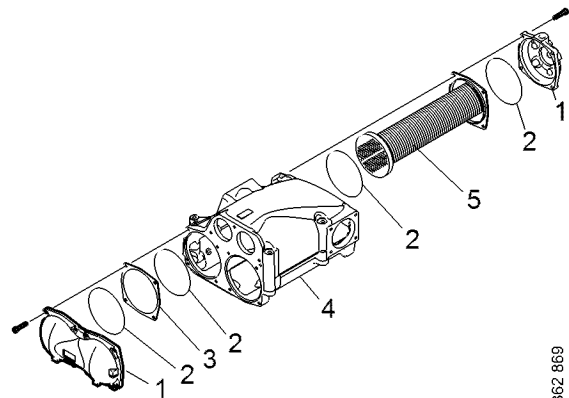

362 869

1. Cover.
2. O-rings.
3. Spacer.
4. Charge air cooler housing.
5. Cooler core.

Removing the heat exchanger

When the heat exchanger core needs cleaning, the heat exchanger must be removed.



WARNING!

Use protective gloves as coolant can cause irritation if it comes in contact with the skin. Hot coolant can also cause scalding.

1. Make sure that the cooling system is empty as described earlier.
2. Remove the sea water pipe between the charge air cooler and heat exchanger.
3. If the engine has a water-cooled exhaust pipe bend: Remove the sea water pipe between the heat exchanger and the exhaust pipe bend.

4. Remove the coolant pipe with the thermostat housing cover.

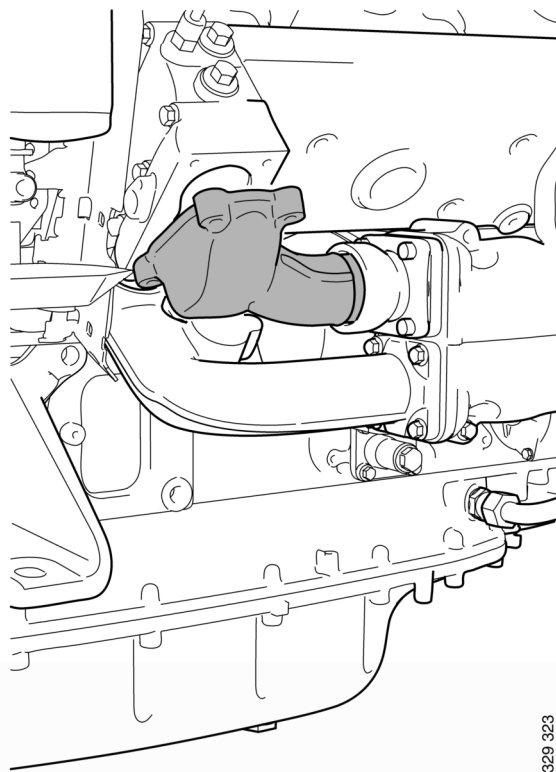

5. Remove the coolant pipe from the heat exchanger.

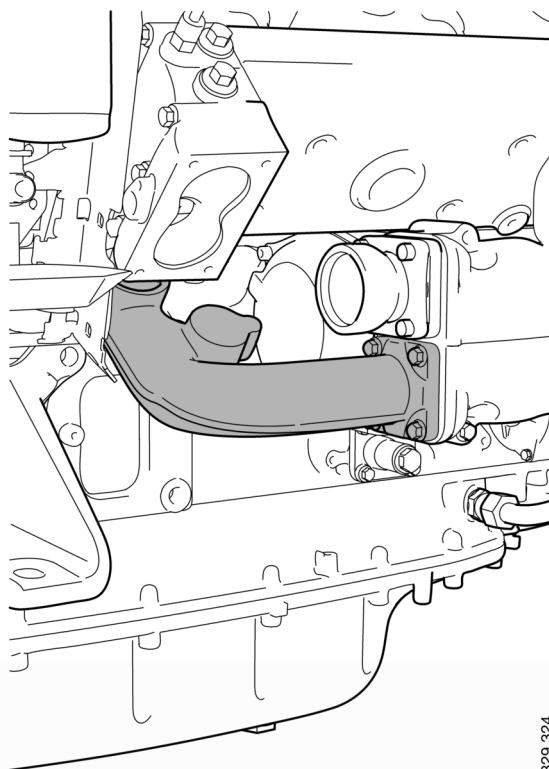

6. Remove the screws on the heat exchanger and the 2 upper screws on the exhaust manifold bracket.

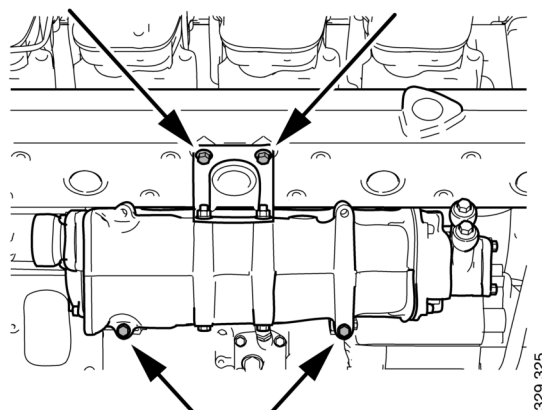

7. Remove the heat exchanger by holding it in the bracket, moving the heat exchanger slightly to the side and removing it.

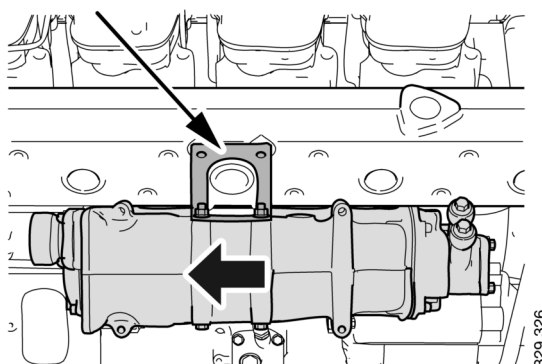

Cleaning the heat exchanger

1. Remove the screws on the heat exchanger covers (1) and remove the covers. Mark the covers so that you can put them back on the correct side.
2. Press in the cooler core (5) slightly on one side and pull it out from the other side.
3. Clean the cooler core on the outside with a slightly acidic detergent, e.g. 2 479 017. Remove any internal deposits using a round rod. Renew the cooler core if it is damaged.



IMPORTANT!

Do not use caustic soda as this could damage the aluminium.

4. Renew the O-rings (3) and assemble the heat exchanger.
5. Tighten the M8 screws on the covers with 15 Nm (11 lb/ft).

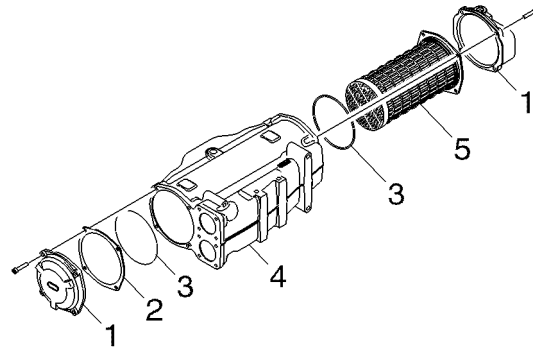

362 870

1. Cover.
2. Spacer.
3. O-rings.
4. Heat exchanger housing.
5. Cooler core.

Fitting the heat exchanger

1. Fit the heat exchanger by holding the bracket for the exhaust manifold, moving it slightly to the side and fitting it.

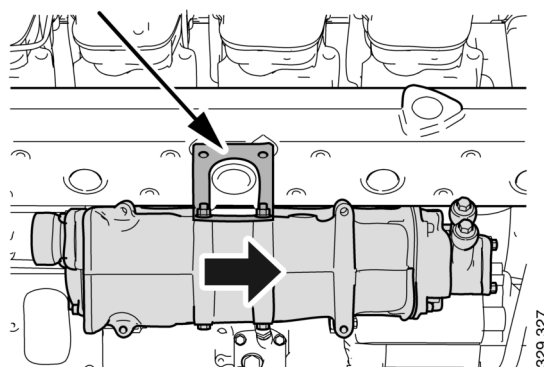

2. Fit all screws by hand and then tighten them. Tightening torque 50 Nm (37 lb/ft).

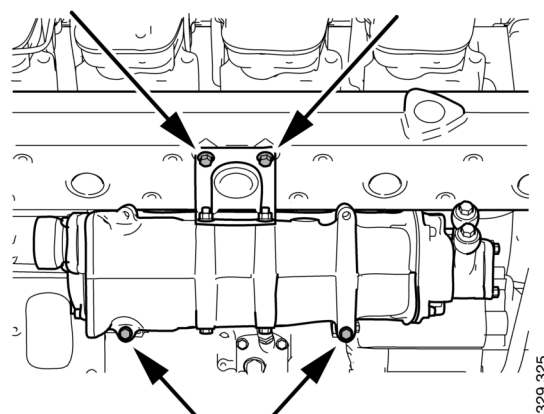

3. Lubricate and fit the coolant pipe from the heat exchanger. Angle the pipe from the thermostat housing inwards and push it onto the connection.

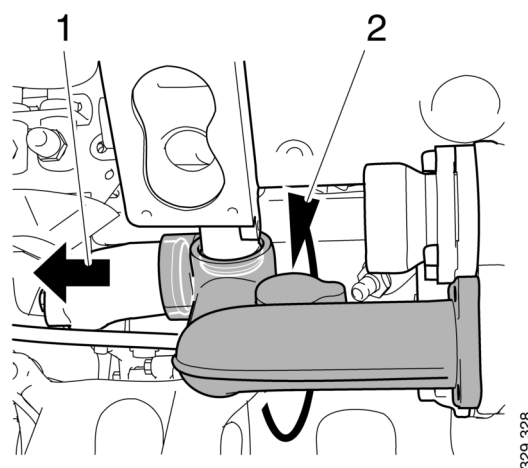

4. Fit the coolant pipe with the thermostat housing cover.

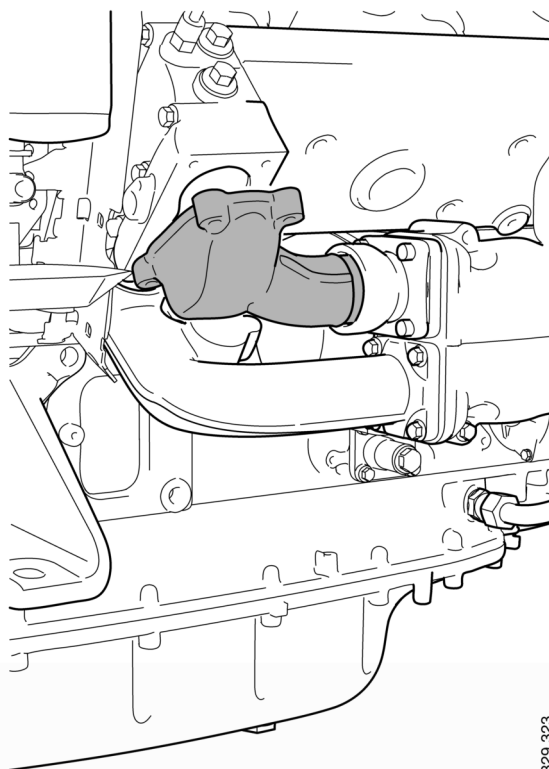

329 323

5. Fit the sea water pipe between the charge air cooler and heat exchanger.
6. If the engine has a water-cooled exhaust pipe bend: Fit the sea water pipe between the heat exchanger and the exhaust pipe bend.

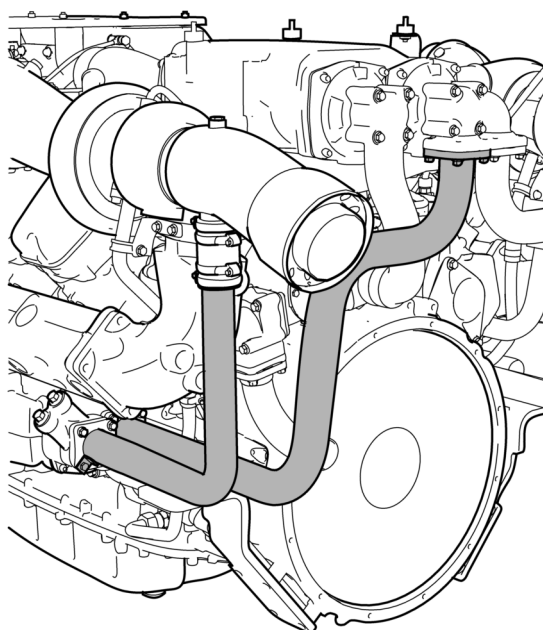

329 322

Fitting the charge air cooler

1. Fit the charge air cooler. Tighten the 4 screws to 50 Nm (37 lb-ft).

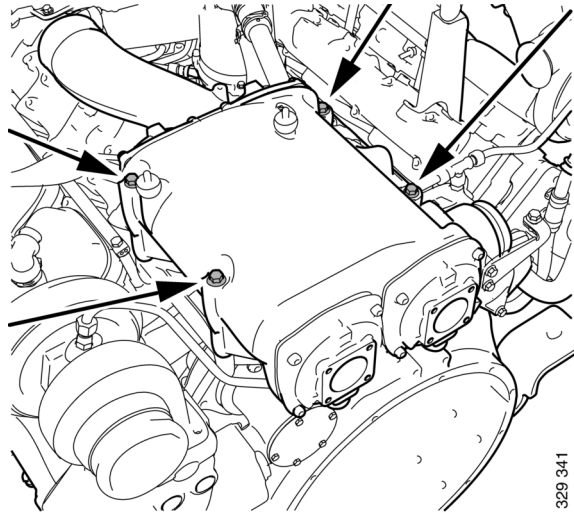

329 341

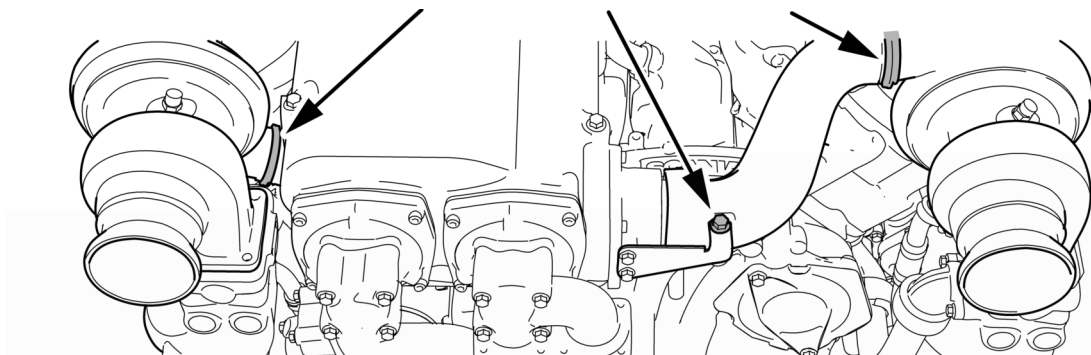

329 318

2. Carefully fit the charge air pipe from the left-hand turbocharger and tighten the V-clamp to 20 Nm (15 lb-ft).
3. Fit the charge air pipe from the right-hand turbocharger. Fit the V-clamp first and then the screw on the bracket.
4. Fit the sea water pipe from the sea water pump, first to the charge air cooler (the inner pipe) and then from the charge air cooler to the heat exchanger (the outer pipe).

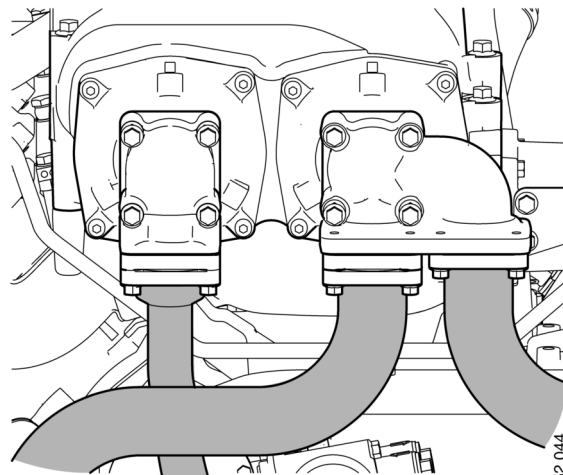

352 044

5. Fit the charge air pipe and the hose clamps.

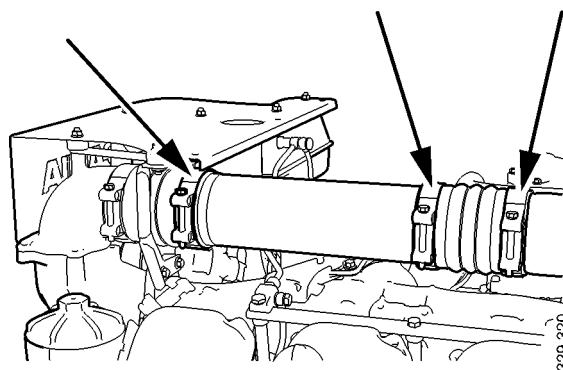

6. Fit the crankcase ventilation hose.

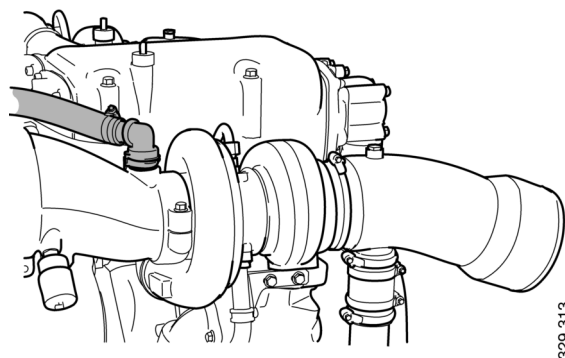

7. Fit the catwalk:

- Loosely fit the protective plate to the charge air pipe. Tighten the screws later.
- Fit the protective casing. Tighten the screws later.
- Fit the catwalk with screws.
- Tighten all screws. The protective plate and protective casing must be tightened to a tightening torque of 15 Nm (11 lb-ft).

Internal: Removing oil and grease



Environment

Use a suitable container. Used coolant must be disposed of as specified in national and international laws and regulations.

Always fit a new thermostat and a new cover to the expansion tank after cleaning, as the oil in the cooling system destroys the seals. If the engine is fitted with a coolant filter, also renew this filter.

It may be necessary to wash it multiple times if the cooling system is very dirty. One cause of contamination can be that oil is lying on top of the coolant and collecting high up in the cooling system. If several rinses are needed, this is not necessarily because work has been carried out incorrectly. Oil residues often need to be rinsed repeatedly from the expansion tank and the external heating system to be completely clean.

Repeated washing is more effective and preferable to using higher concentrations of detergent (max. 10%) or cleaning for a longer period (max 30 minutes).

If only a small amount of dirt has collected in the expansion tank after cleaning, one extra rinse and clean of the expansion tank only is usually sufficient. There is no need to clean the whole cooling system again.

1. Run the engine until it has reached operating temperature if possible and then drain the cooling system following the previous description.
2. Remove the thermostats.
3. Fill the cooling system with clean hot water mixed with detergent 2 479 017. Detergent 2 479 017 must make up 5-10% (depending on the degree of dirt) of the total coolant volume.
If detergent 2 479 017 is not available, use a dishwashing detergent for domestic appliances that does not foam. Concentration 1%.
4. Warm up the engine for approximately 20-30 minutes. Remember to switch on the cab heating system, if one is installed.
5. Drain the cooling system.
6. Fill the cooling system with clean, hot water and run the engine for about 20-30 minutes.
7. Repeat steps 3-6 if the cooling system is not clean.

8. Drain the water from the cooling system.
9. If necessary, clean the expansion tank by detaching all hoses and rinsing and cleaning with a degreasing agent and a dish brush.
Alternatively, dismantle the expansion tank and clean it with water with 10% of detergent 2 479 017. Fill the expansion tank with the mixture, shake it and drain it. Renew the cover of the expansion tank.
10. Refit the thermostats.
11. Fill the cooling system with new coolant as described in the next section.
12. Check again whether further dirt or oil has collected in the expansion tank. Decide whether it is necessary to carry out another full cleaning or whether only rinsing or cleaning of the expansion tank will suffice.

Internal: Removing deposits



Environment

Use a suitable container. Used coolant must be disposed of as specified in national and international laws and regulations.

1. Run the engine until it has reached operating temperature if possible and then drain the cooling system following the previous description.
2. Remove the thermostats.
3. Fill the cooling system with clean hot water mixed with a radiator detergent that is based on sulfamic acid and contains dispersing agents. Follow the manufacturer's instructions for the concentration and cleaning period.
4. Run the engine for the specified time. Remember to switch on the cab heating system, if one is installed.
5. Drain the cooling system.
6. Fill the cooling system with clean, hot water and run the engine for about 20-30 minutes.
7. Drain the water from the cooling system.
8. Refit the thermostats.
9. Fill the cooling system with new coolant as described in the next section.

Filling coolant

This procedure applies when the cooling system has been drained and needs to be filled with a large amount of coolant.

Special tools

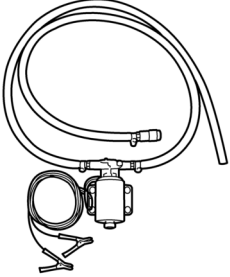
Number, designation	
2 443 679, coolant pump	 <p style="text-align: right; font-size: small;">360 625</p>



WARNING!

Use protective gloves as coolant can cause irritation if it comes in contact with the skin. Hot coolant can also cause scalding.



IMPORTANT!

Mix the coolant as specified in the section headed [Coolant](#).

Never fill a hot engine with a large amount of cold coolant. There is a high risk of cracks forming in the cylinder block and cylinder heads

Do not start the engine until the correct coolant level has been obtained. If the engine is started with engine coolant level low, it can damage the coolant pump shaft seal, which leads to coolant leakage.

1. Open the expansion tank cap.
2. Connect the coolant pump to the filler nipple in the cylinder block.
3. Connect the pump's 2 cable terminals to the battery's negative and positive terminal. Make sure that the filling starts. If the filling does not start: Change the position of the cable terminals.
4. Start the engine and run it at idling for 15 minutes.



IMPORTANT!

It is very important that the engine is idling. Engine overspeed could damage the coolant pump shaft seal, which leads to coolant leakage.

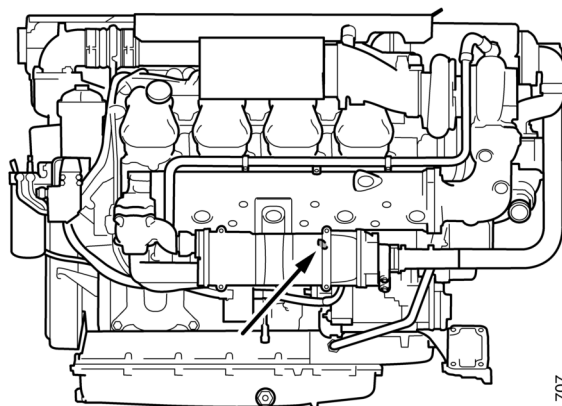

360 707

Filler nipple in the cylinder block (behind the heat exchanger).

5. Switch off the engine and fill with coolant to the maximum level through the expansion tank.

Air pockets may still be left in the cooling system. These will disappear after the engine has been operated for a period of time. Therefore, the coolant may need topping up at a later stage.

Finishing operations

1. Open the sea cock on the sea water inlet.
2. Start the engine and check that there are no leaks.
3. Check the coolant level and top up if necessary via the expansion tank.

Fuel system

Cleanliness requirements



IMPORTANT!

The whole fuel system is very sensitive to dirt and also very small particles. Foreign particles in the system can cause serious malfunctions. It is therefore very important that everything is as clean as possible when work is carried out on the fuel system. Clean the engine before carrying out repair work. If possible, a hot wash should be used.

It is strictly forbidden to carry out any machining work or work with compressed air near an open fuel system.

Be extra careful and always use clean, lint-free and dust-free clothes and gloves when working on the fuel system. Scania recommends using Tegera 848 gloves.

Clean tools before they are used and do not use any worn or chrome-plated tools. Material and flakes of chrome may come off.

Clean connections and the surrounding area before removal. When cleaning, cloths or paper which shed fibres must not be used. Use clean and lint free cloths, part number 588 879.

Plug or cover the connections during removal. Also clean the connections before the components are fitted. Place removed components on a thoroughly cleaned, dust-free surface. Scania recommends using a stainless steel bench top, part number 2 403 296. Cover the components with a lint free cloth.

Checking the fuel level

Check the fuel level and fill with fuel as necessary.

Note:

If the fuel tank has been run dry or if the engine has not been used for a long time, bleed the fuel system. See the section [Bleeding the fuel system](#).

Draining and renewing the water separating prefilter



IMPORTANT!

The sensor cable is sensitive. Handle it carefully.



Environment

Use a suitable container. The fuel collected must be disposed of as specified in national and international laws and regulations.

1. Close the shut-off cock in the fuel pipe and position a container under the filter.
2. Detach the sensor cables from the contact housings (1) on the filters.
3. Open the filter drain plugs (2) and allow the fluid to run down into the container.
4. Unscrew the filters (3) from the filter head (4).
5. Discard the old filters and use new ones.
6. Lubricate the O-rings on the filters with engine oil.
7. Fill the width of the filters with clean fuel.
8. Screw the filters into position until the O-rings rest against the filter head. Tighten the filters another quarter to 3 quarter turn by hand.
9. Open the shut-off cock on the fuel pipe and check that the fuel system is sealed.
10. Connect the sensor cable to the contact housings on the filters.
11. Bleed the fuel system according to the instructions in the [Bleeding the fuel system](#) section.

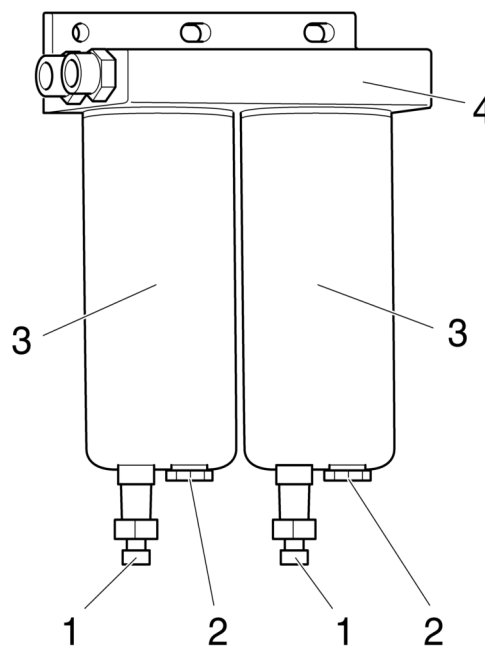

Water separating prefilter.

1. Contact housing.
2. Drain plugs.
3. Filter.
4. Filter head.

354 446

Draining and renewing the single water separating prefilter

IMPORTANT!

The sensor cable is sensitive. Handle it carefully.

Environment

Use a suitable container. The fuel collected must be disposed of as specified in national and international laws and regulations.

Before starting work: Close the shut-off cock in the fuel pipe and position a container under the filter.

1. Detach the sensor cable from the contact housing on the filter bracket.
2. Open the drain tap in the filter cover and let the fluid run down into the container.
3. Unscrew the filter cover.
4. Unscrew the filter from the filter head.
5. Discard the old filter and use a new filter.
6. Lubricate the O-ring in the filter cover with engine oil.
7. Screw the filter cover onto the new filter by hand. Make sure that the drain tap is fully closed.
8. Lubricate the O-ring on the filter with engine oil.
9. Fill the width of the filter with clean fuel.
10. Screw the filter into position until the O-ring rests against the filter head. Tighten the filter another 1/2 to 3/4 turn by hand.
11. Open the shut-off cock on the fuel pipe and check that the fuel system is sealed.
12. Screw the sensor cable in the contact housing onto the filter bracket.
13. Bleed the fuel system according to the instructions in the [Bleeding the fuel system](#) section.

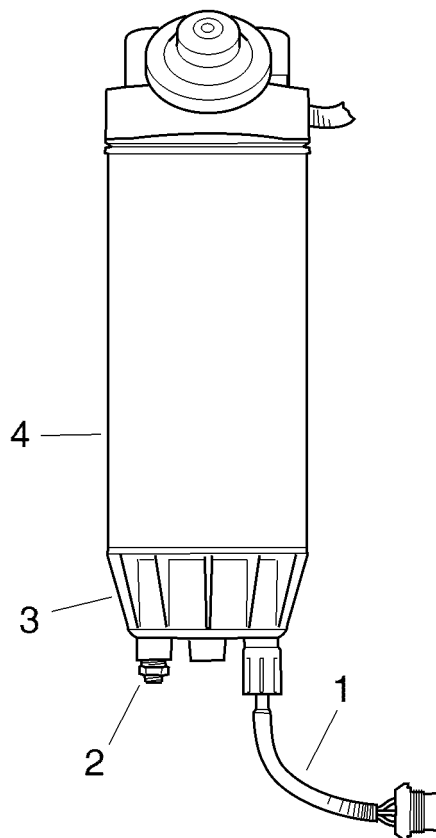

1. Sensor cable.
2. Drain tap.
3. Filter cover.
4. Filter

336 101

Draining the reversible water separating prefilter

During operation, the rotary control should point 90° towards the filter being used.



Environment

Use a suitable container. The fuel collected must be disposed of as specified in national and international laws and regulations.

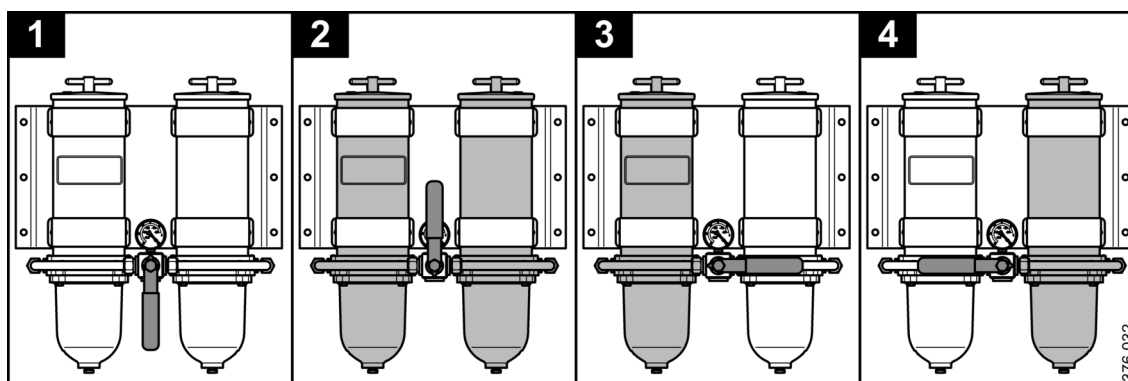

1. Closed, no filters are active.

2. Both filters are active.

3. Left-hand filter is active.

4. Right-hand filter is active

1. Switch off the filter that needs renewing. The arrow on the rotary control should point towards the filter that should remain active during renewal.



WARNING!

Be careful that the valve does not pass the closed position when the engine is in operation. A closed position can result in the engine stopping. In marine applications, the engine stopping represents a safety hazard.

2. Remove the cover from the filter housing.

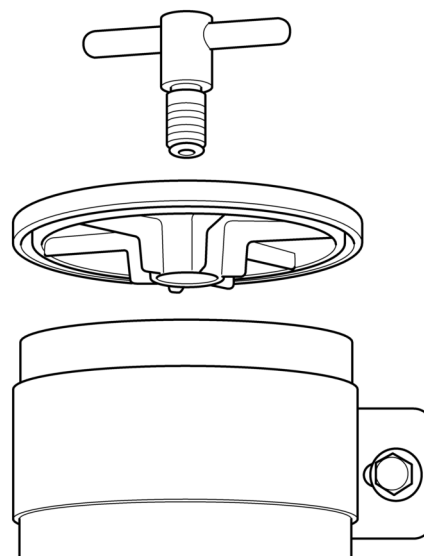

3. Undo the drain plug.
4. Tighten the drain plug when all the water has emptied.

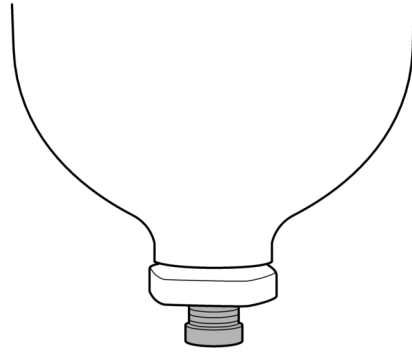

377 156

5. Fill the filter housing with clean fuel.
6. Fit the cover. Tighten the cover screw by hand.

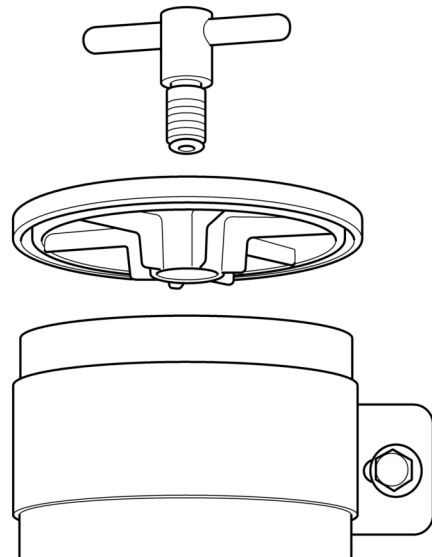

377 154

Renewing the reversible water separating prefilter

During operation, the rotary control should point 90° towards the filter being used.



Environment

Use a suitable container. The fuel collected must be disposed of as specified in national and international laws and regulations.

1. Switch off the filter that needs renewing. The arrow on the rotary control should point towards the filter that should remain active during renewal.



WARNING!

Be careful that the valve does not pass the closed position when the engine is in operation. A closed position can result in the engine stopping. In marine applications, the engine stopping represents a safety hazard.

2. Clean the filter housing externally with a cleaning cloth.
3. Remove the cover from the filter housing.

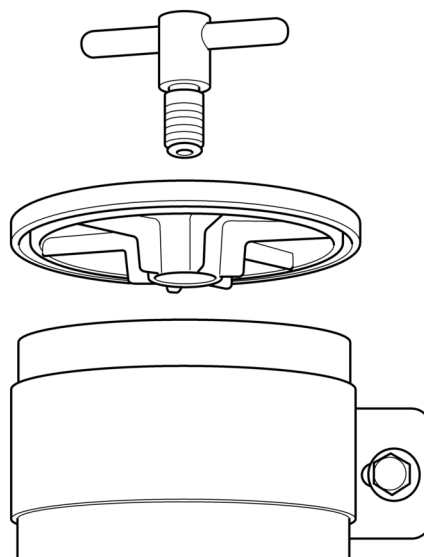

377 154

4. Remove the filter and fit the new filter.

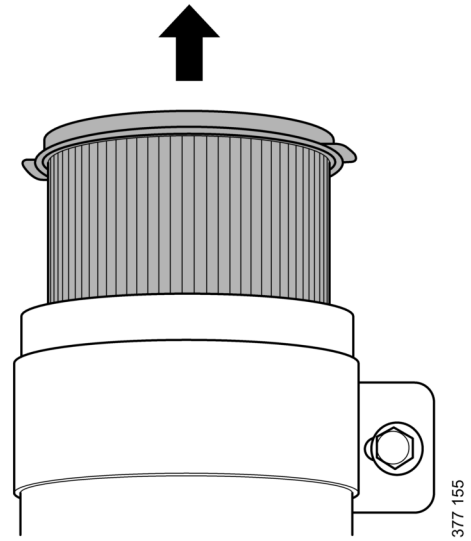

5. Renew the O-rings in the cover.

6. Lubricate the O-rings with engine oil.

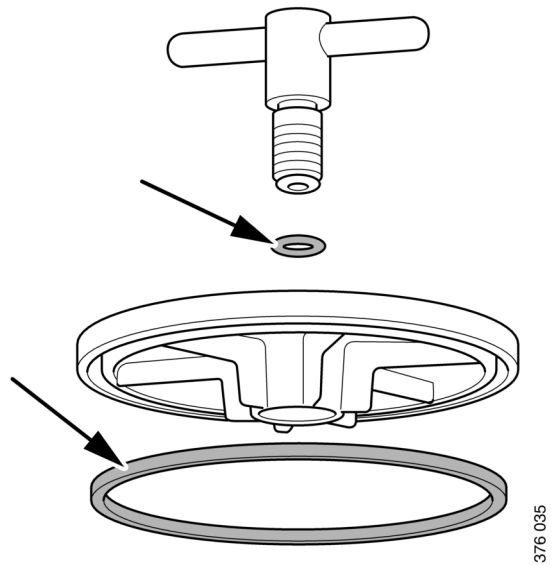

7. Fill the filter housing with clean fuel.

8. Fit the cover. Tighten the cover screw by hand.

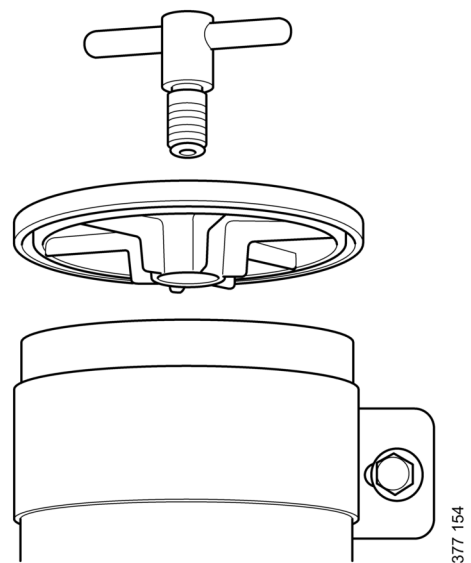

Renewing the reversible fuel filter, 16 litre marine engine with XPI

Tool

Number	Designation
2,002,537	Grease for O-ring



Environment

Since the engine must be running during filter renewal, fuel may spill. Use a suitable container. Collected fuel must be disposed of as specified in national and international law.

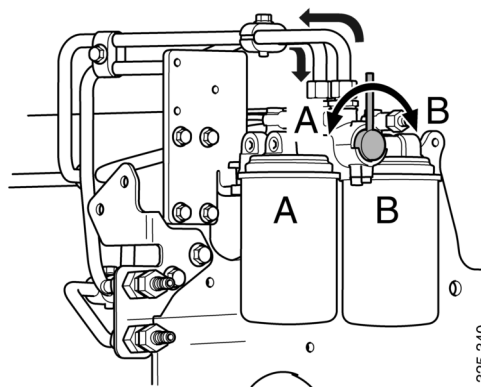

1. Start the motor. During operation, the rotary control should point 90° towards the filter being used.
2. Turn the rotary control 90° to the right so that it points towards filter B. The fuel then flows through the filter.
3. Connect a clear plastic hose to the bleed nipple above filter A. Place the other end in a container with a capacity of at least 3.8 litres (1 US gallon).
4. Open the bleed nipple on side A. The remaining pressure will be released.
5. Clean the exterior of the filter with a cleaning cloth.
6. Unscrew the filter.
7. Apply O-ring grease, part number 2 002 537, to the gasket on the new filter.
8. Screw the filter into place by hand until it makes contact. Turn screw a further half turn by hand.
9. Turn the rotary control 90° to the left so that the rotary control points straight up. Both filters now run simultaneously.
10. When fuel without air bubbles comes out, close the bleed nipple. Tightening torque 9 Nm. Because the engine is running, a lot of fuel will come through the hose.
11. Turn the rotary control 90° to the left so that the pointer is pointing towards filter A. Filter B can then be renewed in the same way as filter A.

Renewing the fuel filter



Environment

Use a suitable container. The fuel collected must be disposed of as specified in national and international laws and regulations.

1. Clean the exterior of the fuel filter with a damp cleaning cloth.
2. Unscrew the filter.
3. Apply oil to the gasket on the new filter.
4. Screw the filter into place by hand until it makes contact.
5. Screw a further half turn by hand.
6. Bleed the fuel system according to the instructions in the following section.

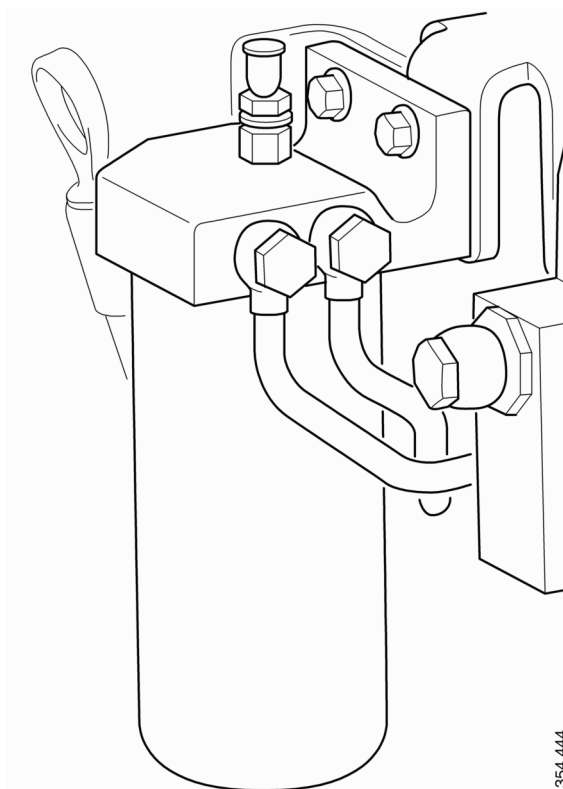

Bleeding the fuel system

Venting the fuel system using a hand pump



Environment

Use a suitable container. The fuel collected must be disposed of as specified in national and international laws and regulations.

1. Loosen the hand pump handle (1).
2. Connect a clear plastic hose to the bleed nipple on the fuel filter (2). Let the plastic hose drop into a container that holds at least 5 litres (1.3 US gallons).
3. Open the bleed nipple on the fuel filter.
4. Pump with the hand pump until fuel comes out.
5. Close the bleed nipple on the fuel filter.

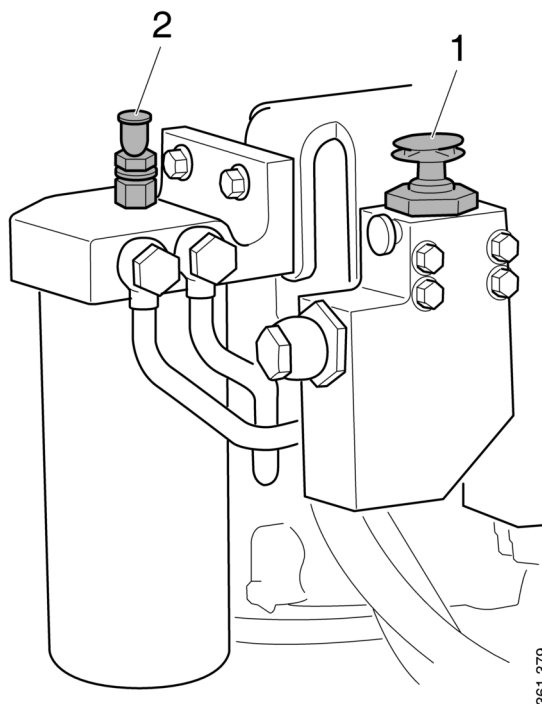

361 379

6. Connect a clear plastic hose to the bleed nipple on the high pressure pump (3). Let the plastic hose drop into a container that holds at least 5 litres (1.3 US gallons).
7. Open the bleed nipple on the high pressure pump and pump the hand pump until fuel comes out. It will take around 150 pump strokes.
8. Close the bleed nipple on the high pressure pump and screw down the hand pump handle.
9. Start the motor. The motor should be easy to start.

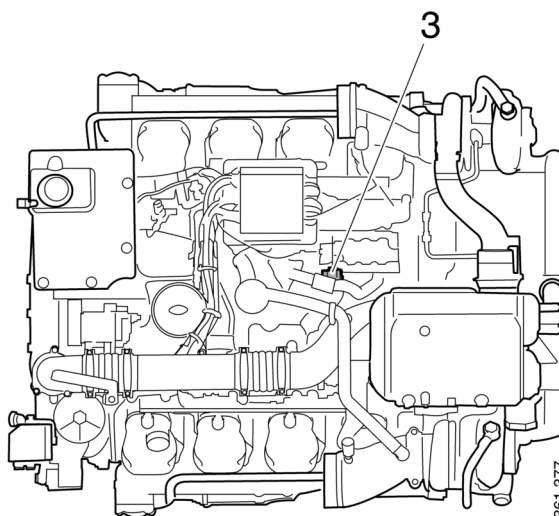

361 377

Venting the fuel system using a suction tool

Tool

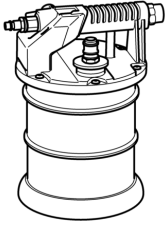
Designation	Illustration
Suction tool for fuel system	 337 297



Environment

Use a suitable container. The fuel collected must be disposed of as specified in national and international laws and regulations.

1. Open the bleed nipple on the high pressure pump (3) and connect the suction tool to it.
2. Hold the suction tool straight and draw out a full container of fuel.
3. Once the fuel coming out of the hose is free of air bubbles, then venting is complete.
4. Close the bleed nipple on the high pressure pump. Remove the hose and suction tool.
5. Start the engine and check that there are no leaks.

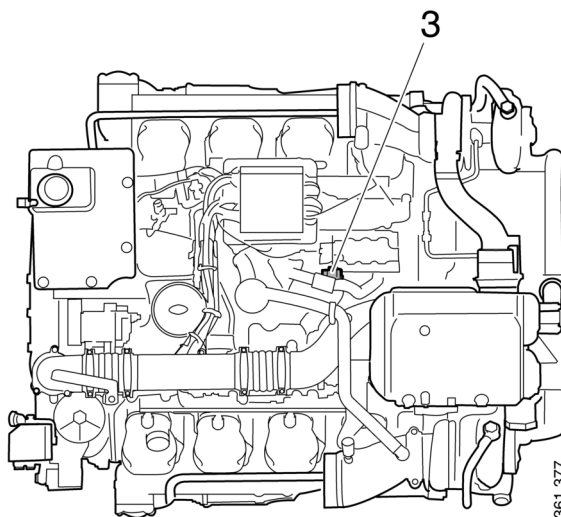

Bleeding the fuel system using a hand pump, 16 litre marine engine, XPI



Environment

Use a suitable container. Collected fuel must be disposed of as specified in national and international law.

1. Turn the rotary control so that it points towards filter B. The fuel then flows through the filter.

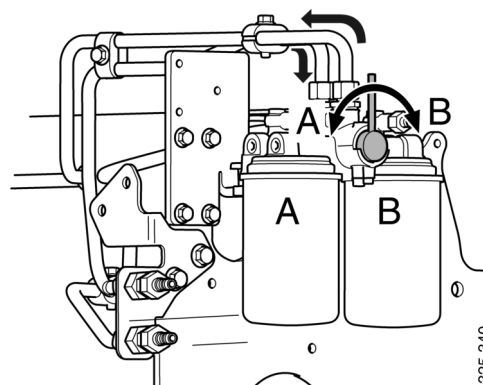

2. Unscrew the hand pump handle (1) and connect a transparent plastic hose to the bleed nipple on the fuel filter (2). Let the plastic hose drop into a container that holds at least 5 litres (1.3 US gallons).
3. Open the bleed nipple on the fuel filter.
4. Pump with the hand pump until fuel without bubbles comes out.
5. Close the bleed nipple on the fuel filter. Tightening torque 9 Nm.
6. Connect a clear plastic hose to the bleed nipple on the high pressure pump (3). Let the plastic hose drop into a container that holds at least 5 litres (1.3 US gallons).

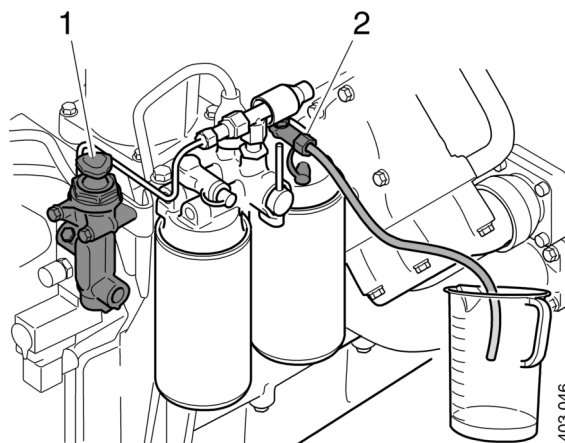

7. Open the bleed nipple on the high pressure pump and pump the hand pump until fuel without bubbles comes out. It will take around 150 pump strokes.
8. Close the bleed nipple (3 in the illustration) on the high pressure pump. Tightening torque 9 Nm. Screw down the hand pump handle.

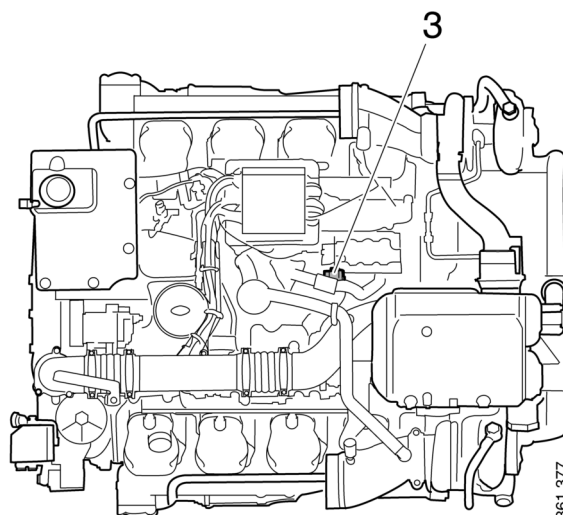

9. Start the motor. The motor should be easy to start.

Other

Checking the drive belt



IMPORTANT!

Refit the drive belt with the same direction of rotation as it had before removal.

1. Check the drive belt thoroughly, particularly at the idler rollers.
2. Check the drive belt for cracks. Renew the drive belt if deep cracks have formed.

Note:

Small and shallow cracks are normal and form after only a few hours of operation. They do not mean that the drive belt needs to be renewed. However, if there are many, deep cracks, the drive belt must be renewed. See the illustrations.

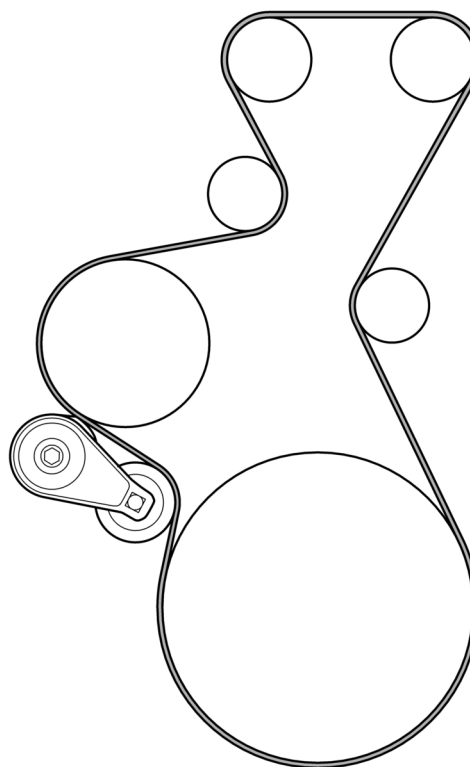

381 628

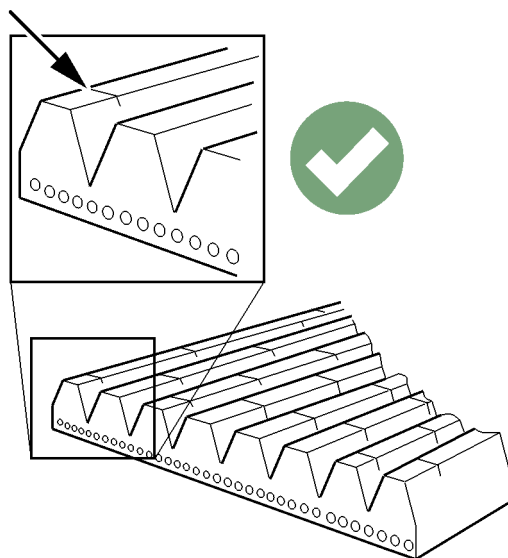

456 936

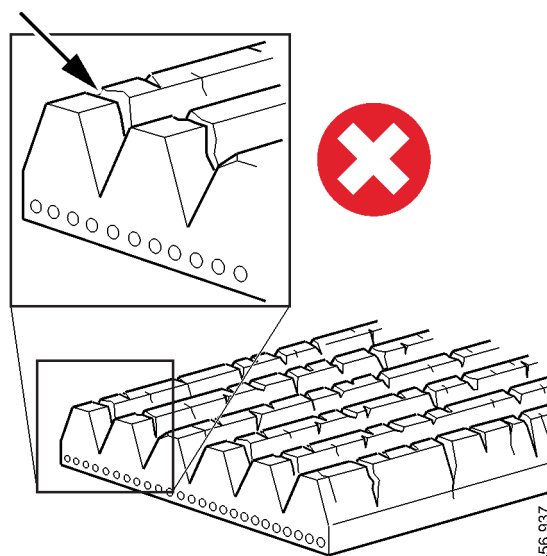

456 937

Example of a minor crack in the drive belt. The drive belt can be refitted.

The drive belt has deep cracks and must be renewed.

3. Check drive belt wear. Renew the drive belt if it is too worn.

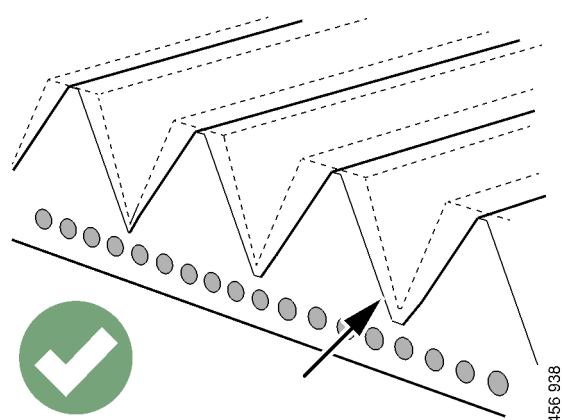

The drive belt is starting to become worn, but can be refitted.

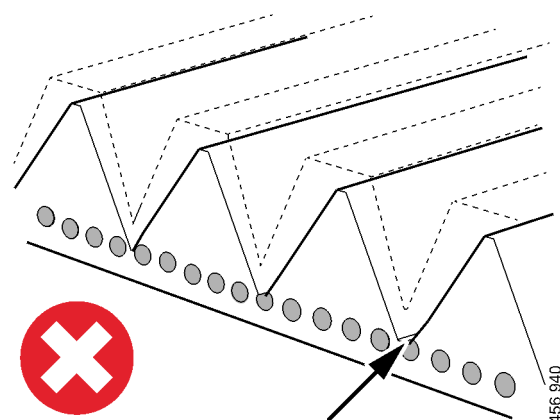

The belt is worn down to the cord. The drive belt must be renewed.

Checking for leakage

IMPORTANT!

If serious leakage occurs, contact your nearest Scania workshop.

1. Start the motor.
2. Check for leaks in the lubrication, intake, cooling, fuel, or exhaust system.
3. Tighten or renew leaking connections. Check the overflow holes which show whether the O-rings between the cylinder liners and crankcase are leaking.

Checking and adjusting the valve clearance

Special tools

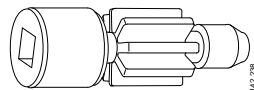
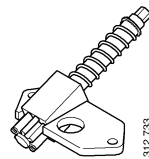
Number	Designation	Figure
99 309	Turning tool for rotating the flywheel from below	
2 402 509	Turning tool for rotating the flywheel from above	

Other tools
Torque wrench, 0-50 Nm
Waterproof felt-tip pen
0.45 and 0.70 mm feeler gauges
Flash light
Mirror



WARNING!

Block the starting device. If the engine starts unexpectedly, there is a serious risk of injury.



IMPORTANT!

The engine must be cold when the work is carried out.

Remember to remove the turning tool from the flywheel following adjustment.

Note:

Carry out the working without pausing, so that no step is overlooked.

Carry out a check and adjustment of the valve clearances one more time after the first 500 hours of operation. After this, adjustment according to the regular interval takes place, which is every 2,000 operational hours.

The reference information UP TDC, DOWN TDC and the angle indications listed in the table below are engraved on the flywheel. Depending on the engine installation and type of flywheel housing, this information is visible in one of the windows, either furthest up or furthest down on the flywheel. See illustration.

Valve clearance, specifications	
Intake valve	0.45 mm (0.018 in)
Exhaust valve	0.70 mm (0.028 in)

Tightening torque	
Lock nut for valves	35 Nm (26 lb/ft)

Adjust the valves according to the table below. Follow the respective column depending on whether you are reading the engraving on the flywheel in the lower or the upper window. Start adjustment at the top of the table.

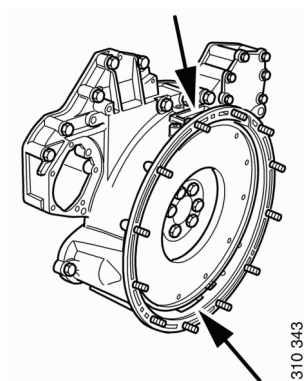

Order of cylinders

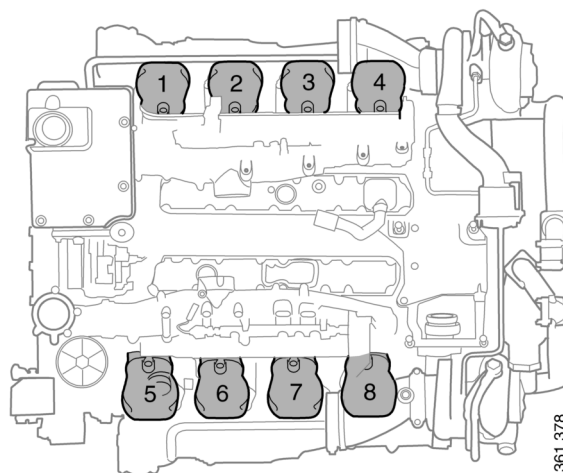

Upper and lower window to read the engraving on the flywheel.

Reading in the lower window	Valve transition on cylinder	Adjust intake valve on cylinder	Adjust exhaust valve on cylinder	Reading in the upper window
DOWN TDC (0°)	6	7 and 8	4 and 5	UP TDC (180°)
UP TDC (180°)	7	1 and 5	2 and 6	DOWN TDC (0°)
DOWN TDC (360°)	1	2 and 4	3 and 7	UP TDC (540°)
UP TDC (540°)	4	3 and 6	1 and 8	DOWN TDC (360°)

1. Clean the rocker covers and the area around them.
2. Remove the rocker covers.
3. In order to rotate the flywheel, use a turning tool compatible with the installation of the engine, i.e. whether access is from above or from underneath. Use any specified special tool or the equivalent from another supplier.
4. Start adjusting one cylinder according to the table. Rotate the flywheel until the correct engraving can be read on the flywheel. It may be necessary to rotate it more than 1 revolution.

Rotate the flywheel in the rotational direction of the engine, which is clockwise viewed from the front of the engine and anti-clockwise viewed from the back of the engine.

During a valve transition, the exhaust valve (the long arm) is closing at the same time as the intake valve is opening.

The UP TDC engraving on the flywheel is now visible in the window furthest up on the flywheel. The DOWN TDC engraving is visible in the lower window.

5. Read the table on the previous page to see which valve to adjust.
6. Stick the feeler gauge under the pressure pad of the rocker arm and check the valve clearance.
7. If necessary, adjust the valve clearance by
 - a) loosening the lock nut on the end of the rocker arm
 - b) adjusting the valve clearance with the adjusting screw
 - c) tightening the lock nut.
8. Mark the rocker arm with the felt-tip pen and then continue with the next cylinder according to the table.

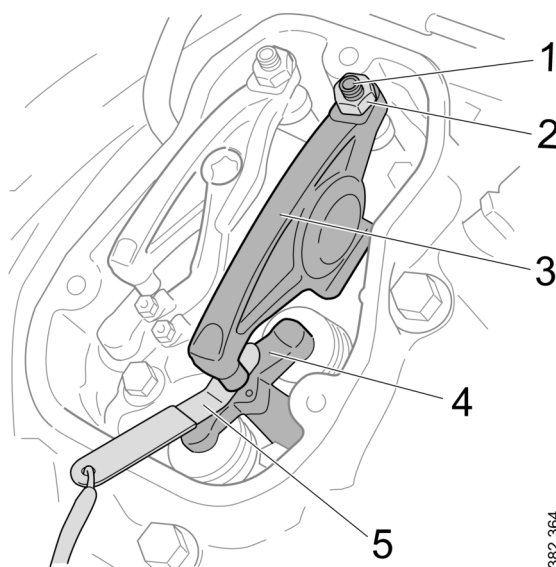

1. Adjusting screw
2. Lock nut
3. Rocker arm
4. Valve bridge
5. Feeler gauge

382 364

Quality requirements for fuel

Quality requirements and testing standards for the most important properties of different types of fuel are described in the Workshop Manual. This can be ordered from Scania dealers or directly from Scania.

Diesel

Characteristics

The quality of the diesel is very important for the operation and service life of the engine and the fuel system, and also for the engine performance.



REQUIREMENT!

The diesel should comply with the requirements of European standards EN590 or EN15940.

However, Scania accepts larger tolerances of certain properties. Please see the table below.

Characteristic	Requirements
Viscosity at 40°C (104°F)	1.4-4.5 cSt
Density at 15°C (59°F)	0.79-0.87 kg/dm ³
Ignitability (CET rating)	minimum 49
Lowest flashpoint	56°C (132°F)
Particulate contamination level	Classification 22/20/17 according to ISO 4406

Permitted sulphur content in diesel



IMPORTANT!

The operator is responsible for using the correct type of diesel to ensure that local laws are complied with.

Sulphur content in diesel	Note
0-2,000 ppm (<0.2%)	Normal oil change interval of up to 500 hours.
2,000-4,000 ppm (0.2-0.4%)	The oil change interval must be halved to a maximum of 250 hours.
4,000 ppm (0.4%)	Max. permitted sulphur content. If diesel with too high a sulphur content is used, this causes engine damage.

Temperature dependence of diesel



IMPORTANT!

Mixing kerosene or other paraffins with the diesel is prohibited. The injectors may be damaged.

It is not permissible to mix petrol with diesel. In the long term petrol can cause wear in the injectors and engine.

At temperatures lower than those specified for the diesel, paraffin wax may precipitate from the diesel and block filters and pipes. The engine can then lose power or stop.

The diesel is adapted for use in the specific climate of each country. If an engine is to be operated in a temperature zone with a temperature lower than normal, first identify the temperature properties of that particular diesel.

Biodiesel (FAME)

Use of biodiesel



IMPORTANT!

For engines with SCR systems, a maximum of 10% mixture of biodiesel should be used.

Scania uses the term biodiesel to refer to a renewable diesel made from greases or oils and methanol. The biodiesel should conform to the requirements of European standard EN 14214 or Brazilian standard ANP-45. For biodiesel in accordance with EN 14214 or ANP-45, the generic term FAME is frequently used.

Normal diesel in accordance with EN 590 can contain up to 7% biodiesel from the diesel supplier. There are grades of diesel that comply with EN 590 but contain a higher mixture of biodiesel.

Scania approves up to a 10% mixture of biodiesel for all engines.

For PDE engines, Scania approves the use of up to 100% biodiesel in accordance with EN 14214 or ANP-45. However, this does not apply to engines with an SCR system, for which only a 10% mixture is permitted.

Maintenance interval



IMPORTANT!

Make sure that maintenance intervals are different when operating on diesel or biodiesel.

With a greater mixture of biodiesel than 10%, the renewal intervals for the following are halved:

- Fuel filter.
- Oil filter.
- Engine oil.

The viscosity grade of the engine oil should be xW-40. xW-30 grade oils are unsuitable due to the fuel dilution effect.

Check the engine oil level regularly. If the oil level exceeds the maximum level, the oil must be changed. Check the cause if the oil level exceeds the maximum level and contact your nearest Scania workshop if you suspect a fault.

Storage of biodiesel



IMPORTANT!

Biodiesel must not be stored for more than 6 months.

Biodiesel has a maximum storage life of 6 months from the date of production to the expiry date. The fuel is affected by light, temperature, water, etc. during storage, which affects the fuel characteristics and durability.

Biodiesel also has lower stability against oxidation than diesel. This may result in a thickening of the fuel and clogging of parts of the fuel system, e.g. the fuel filter. Bacterial growth can occur when biodiesel is stored in a tank in unfavourable conditions. Avoid storage in barrels or auxiliary tanks, except when fuel turnover rates are high. Check tank cleanliness whenever refuelling takes place.

If the engine has been refuelled with biodiesel, and is stationary for a long period, condensation water can form in the fuel tank resulting in bacterial growth.

See also the section [Preservative fuel](#).

Renewable diesel (HVO)

HVO is a synthetic diesel which is manufactured through the hydrogenation of plants and animal fats. To the user, HVO is reminiscent of diesel in accordance with EN590, apart from HVO having a somewhat lower density.

Scania approves the use of up to 100% HVO for all engines in accordance with the European standard EN 15940.

Gas-to-liquids (GTL)

GTL is a synthetic fuel that is often refined from natural gas. To the user, GTL is reminiscent of diesel in accordance with EN590, apart from GTL having a somewhat lower density and less odour.

Scania approves the use of up to 100% GTL in accordance with the European standard EN 15940.

Preparing the engine for storage

Note:

The engine should be stored indoors, in a temperature-controlled room with constant (or near constant) temperature, protected from dirt and dust.

If the engine is not being used for an extended period its cooling system, fuel system and combustion chamber and outside must be protected against rust.

On delivery, the engine is protected by so-called VCI plastic. Provided that the VCI bag is intact and has not been removed, the engine can be stored for 3 years without any action required. After 3 years, the engine must be preserved again and the battery must be renewed.

The interval between each new Preparing for storage is then 24 months and the bag is renewed.

The VCI bag must be inspected at least once a year. If the plastic is missing or broken, it must be replaced with a new one immediately.

An alternative to preparing the engine for long-term storage is to start the engine and warm it up every 6 months.

Preparation means that the following measures are taken:

- The engine is cleaned thoroughly.
- Run the engine for a specific period using special preservative fuel, oil and coolant.
- Otherwise prepare the engine for storage (filter renewal, lubrication, etc.).

Preservative products

Preservative oil

Use a normal engine oil that meets the requirements in the section Oil grade.

Preservative coolant

Use coolant containing 50% by volume of glycol. Example: BASF MPG Glyscorr P113 and Valvoline Zerex P113 FP.



WARNING!

Ethylene glycol can be fatal if ingested and can cause skin irritation and eye damage.

Preservative fuel

Preservative fuel must not contain biodiesel. Even small amounts of 5-10% biodiesel can have adverse effects on the engine when in long-term storage.

Long-term storage of diesel, where the diesel comes into contact with water, may lead to the growth of micro organisms (bacteria and fungus).

In order to minimise the growth of micro-organisms, preservative fuel should contain the following additives. The additives should be selected and added by the fuel supplier.

Preservative fuel should comply with the following requirements:

- 0% biodiesel.
- Max. sulphur content 50 ppm.
- Max. water content 200 ppm.
- The fuel must contain additives to stop the growth of micro-organisms.

Preparations for storage



Environment

Use a suitable container. Used oil and coolant must be disposed of as specified in national and international laws and regulations.

Note:

Do not remove the injectors.

1. Remove plugs and tape from the coolant connections, air intake and exhaust pipe.
2. Drain the oil.
3. Renew the oil filter and fuel filter.
4. Clean the centrifugal oil cleaner.
5. Fill with engine oil to the minimum level on the oil dipstick.
6. Drain and flush the cooling system of any old coolant.
7. Top up with preservative coolant.
8. Mix preservative fuel in a can. Detach the fuel pipe at the feed pump suction line and connect a hose from the can.
9. Detach the fuel pipe at the overflow valve and connect a return hose to a separate can.
10. Connect and bleed the fuel system.
11. Start the engine and run it at about 1,100 rpm for 20 minutes.
12. Remove the rocker covers and lubricate the valve mechanisms with pushrods and the valve tappets, as well as the injector mechanism, using a liberal amount of preservative oil. Refit the rocker covers.
13. Drain the coolant if the engine is not to be stored with coolant in the system. Plug and tape all coolant connections if the engine is to be stored without coolant in the cooling system.
14. Remove the sea water pump impeller.
15. Renew the filter element in the air cleaner.
16. Cover the air intake and exhaust pipe.
17. Spray the outside of the alternator and starter motor with water-repellent anti-corrosive oil: CRC 226, LPS1 or equivalent.
18. Spray the outside of smooth engine parts, first with penetrating preservative oil such as Dinitrol 25B and then with Dinitrol 112 or equivalent.
19. Clearly mark the engine with the storage preparation date, and state that the engine must not be started or cranked.

Batteries



WARNING!

Wear protective gloves and eye protection when charging and handling batteries. The batteries contain a highly corrosive acid.

Remove the batteries and trickle charge them at the battery charging station. This does not apply to batteries specified as maintenance-free by the manufacturer.

The same applies to short-term storage, even if the engine has not been prepared for storage as above.

Storage

After the preparation, the engine should be stored indoors in a dry location at room temperature. The engine must be packed in packaging made of VCI plastic to protect against dust, dirt and moisture.

When the engine is to be taken into operation again

1. Remove plugs and tape from the coolant connections, air intake and exhaust pipe.
2. Fill the cooling system with coolant.
3. Fit the sea water pump impeller.
4. Drain the preservative oil.
5. Renew the oil filter and fuel filter.
6. Fill with new engine oil.
7. Remove the rocker covers and lubricate the valve mechanisms with pushrods and the valve tappets, as well as the injector mechanism, using a liberal amount of oil. Refit the rocker covers.
8. Drain the preservative fuel from the fuel manifold.
9. Connect and bleed the fuel system.
10. Wash off any preservative oil on the outside using white spirit.

Technical data

General data

Number of cylinders and configuration	V 8
Working principle	4-stroke engine
Cylinder diameter (mm/in)	130/5.12
Piston stroke (mm/in)	154/6.1
Displacement (dm ³ /in ³)	16.4/1,001
Firing order	1 - 5 - 4 - 2 - 6 - 3 - 7 - 8
Compression ratio	16.7:1
Engine direction of rotation viewed from rear	Anticlockwise
Fan direction of rotation viewed from front	Clockwise
Cooling	Coolant
Valve clearances, cold engine	
Intake valve (mm/in)	0.45/0.018
Outlet valve (mm/in)	0.70/0.028
Number of teeth on the flywheel	158
Low idling (rpm)	500-1,050
Maximum full-load speed (rpm)	2,300
Fuel	Diesel
Approximate weight, without coolant and oil (kg/lb)	1,660/3,660

Lubrication system

Oil volume	See Maintenance
Oil cleaning	Centrifugal oil cleaning
Oil cooler	Coolant cooled, full flow
Oil filter	Paper filter, full flow
Interval between oil changes (h)	500
Oil grade	
Engines run on low-sulphur fuel	ACEA E5 or E7
Engines not run on low-sulphur fuel	Total Base Number (TBN) > 12 (ASTM D2896)
Oil pressure (bar/psi)	
Normal with the engine at operating temperature, operating speed	3-6/43.5-87
Minimum permitted at idling speed	0.7/10.2
Crankcase pressure (mbar/psi)	-5.4 to 2.0/-0.08 to 0.03

Intake system

Permissible pressure drop in the intake system with cleaned or new filter (mbar/psi)	30/0.44
Permissible pressure drop in the intake system with blocked (dirty) filter (mbar/psi)	65/0.94

Cooling system

Coolant	See chapter Coolant
Coolant volume, excluding radiator (dm ³ /US gallon)	65/17.2
Coolant temperature (°C/°F)	86-94/187-201
Number of thermostats	2
Thermostat opening temperature (°C/°F)	82/180

Fuel system

Injection system	XPI
Engine management system	EMS
Fuel filter	Scania polymer filter
Water separating prefilter	Scania polymer filter

Electrical system

Type	2-pin, 24 V, DC
Starter motor, standard equipment	2-pin, 24 V, 7.0 kW
Alternator, standard equipment	2-pin, 28 V, 100 A

Material content

The values indicate an approximate percentage for the different materials that make up the engine.

Material	% by weight
Steels	40
Cast iron (30% recycled)	46
Aluminium	8
Copper, bronze, brass, zinc	1.5
Lead	<0.1
Plastic	<1
Rubber	<1
Glass	0
Colours	<1
Oils and greases	3

Recycling

Type of material	Recommended recycling method
Metal	Recycling.
Plastic	Recycling, combustion.
Chemicals and oils	Re-use if possible; otherwise hand in to an authorised waste disposal contractor.
Fuel filter and oil filter	Hand in to an authorised waste disposal contractor.
Colour	No known recycling methods.
Electronics	Hand in to an authorised waste disposal contractor.

Tightening torque for screw joint

Screws and nuts

Hexagon screws, hexagon socket screws, Torx screws, hexagon nuts

Metric thread. Strength class 8.8/8.

Thread	Tightening torque	
	Nm	Lb-ft
M4	2.9	21
M5	6	4
M6	9.5	7
M8	24	18
M10	47	35
M12	84	62
M14	135	100
M16	210	155
M18	290	214
M20	420	310
M22	580	428
M24	730	538

Flange screws with hexagonal head and hexagonal flange nuts

Metric thread. Strength class 8.8/8.

Thread	Tightening torque	
	Nm	Lb-ft
M5	6.7	5
M6	10.2	8
M8	26	19
M10	50	37
M12	92	38
M14	149	110
M16	184	136

Hose clamps

Specifications in the tables show tightening torque when tightening by hand.

Note:

The maximum tightening torque for a new unfitted hose clamp is 1 Nm (0.7 lb-ft).

A = width (mm)	Tightening torque	
	Nm	Lb-ft
7.5-9	1.5	1
12	5	4
20	10	7
25	20	15

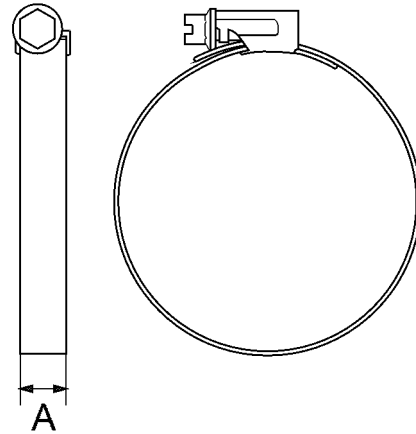

456 919

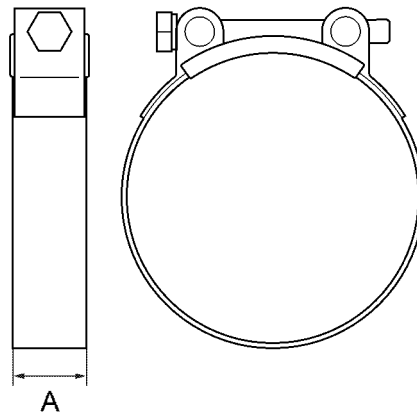

456 920

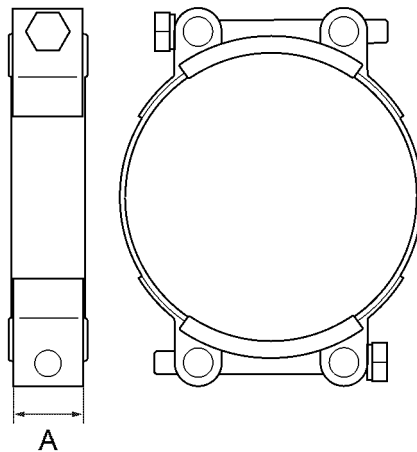

456 921

Scania Assistance

Wherever you are, you can always get assistance from Scania's service organisation, Scania Assistance, 24 hours a day, every day of the year.

Always call the contact for your country.

Country	Tel.	Country	Tel.
Austria	+43 1 256 44 11	Latvia	+371 29 44 24 24
America	+1 (0) 800 272 2642	Lithuania	+46 8 52 24 24 24
America	1 800 272 2642	Luxembourg	+32 2 264 00 00
Argentina	800,999,722,642	Malaysia	1800 08 8500
Australia	+611300722642	Malaysia	+6035590907
Belgium	+32 2 264 00 00	Mexico	+543327451092
Botswana	+267 72 102 591	Morocco	+3222640000
Brazil	+8000194224	Namibia	+264634461352
Bulgaria	+359 88 666 0001	Netherlands	+31 76 52 54 111
Chile	188,800,722,642	Norway	+47 223 217 00
Colombia	+1800184548	Peru	0800-51-727
Czech Republic	+420,225,020,225	Peru	(01)512-1877
Denmark	+45 333 270 44	Poland	+48 22 331 22 33
Estonia	Tallinn: +372 5153 388	Portugal	+34 91 678 9247
Estonia	Tartu: +372 5126 333	Romania	+40 723 27 27 26
Estonia	Pämu: +372 5071 477	Russia	+7(495) 925 77 75
Estonia	Rakvere: +372 5074 655	Singapore	+6565917180
Finland	+358 10 555 24	Slovakia	+421,903,722,048
France	+33 2 414 132 32	South Africa	0 800 005 798
Germany	+49 261 887 8888	South Africa	+27 11 226 5005
Great Britain	0 800 800 660	Spain	+34 91 678 80 58
Great Britain	+441274301260	Sweden	+46 42 100 100
Hungary	+36,209,727,197	Switzerland	+41 800 55 24 00
Ireland	+353 71 963 4000	Thailand	+66819397525
Italy	+39046 1996222	Thailand	+1800 019 88
Latvia	+46 8 52 24 24 24	Uruguay	0 800 835 1

Other countries: +46 8 52 24 24 24

Note:

Calls will be recorded for training purposes.